

CARON since 1960

Caron is a company in Vicenza developed over the years by specializing exclusively in the production of off-road transport vehicles. Born from a mechanical workshop building special platforms for application to mowers and engine driven cultivators, near the end of the '60s Caron evolved through the design of the first transport vehicles with off-road characteristics. Caron has always concentrated its resources in this particular sector, achieving levels of experience that guarantee the delivery of avant-garde products expressing the essence of quality and efficiency. Caron has been developing its range of products close to the real needs of increasingly demanding customers who need to easily but safely work. The specific axles and gears and every other mechanical structure component in these vehicles are developed by Caron: that means highest reliability and performances.

Nowadays CARON is one of the leading manufacturers of transporters in the world.



CARON



CARON[®]
forward-thinking attitude



CT-CTA-CTS
80/110.EUG

CT-CTA-CTS

80/110.EU6



CARON Transporters are innovative multi utility vehicles designed to reliably and efficiently face several uses, the most profitable investment throughout the year. Strength point of CARON products has always been the specific project of gearboxes and axles to optimize weights' distribution and to develop an extremely balanced vehicle with a low centre of gravity, aiming at the highest stability and safety also on the steepest grounds.

Models CT, CTA and CTS are the result of more than 50 years' experience in the manufacturing of this kind of vehicles, expression of technology and reliability, with performance at the top of their category.

Highest Speed up to 60 km/h

Total Weight of 10.000 kg and towing weight up to 14.000 kg



Tractor European Approval

Engines powers from 75 up to 110 HP



Agricolo e forestale Agriculture and Forestry Agricultura y silvicultura

Thanks to their perfect weight balance, the low centre of gravity and the high loading capacity, CARON vehicles can safely work in places otherwise inaccessible to traditional agricultural vehicles with trailer or towed equipment. The several available configurations of hydraulic versions, powers take off (pto) and equipment connections allow the assembly of different overhanging and attached equipment.

Agricultural and Forestry uses

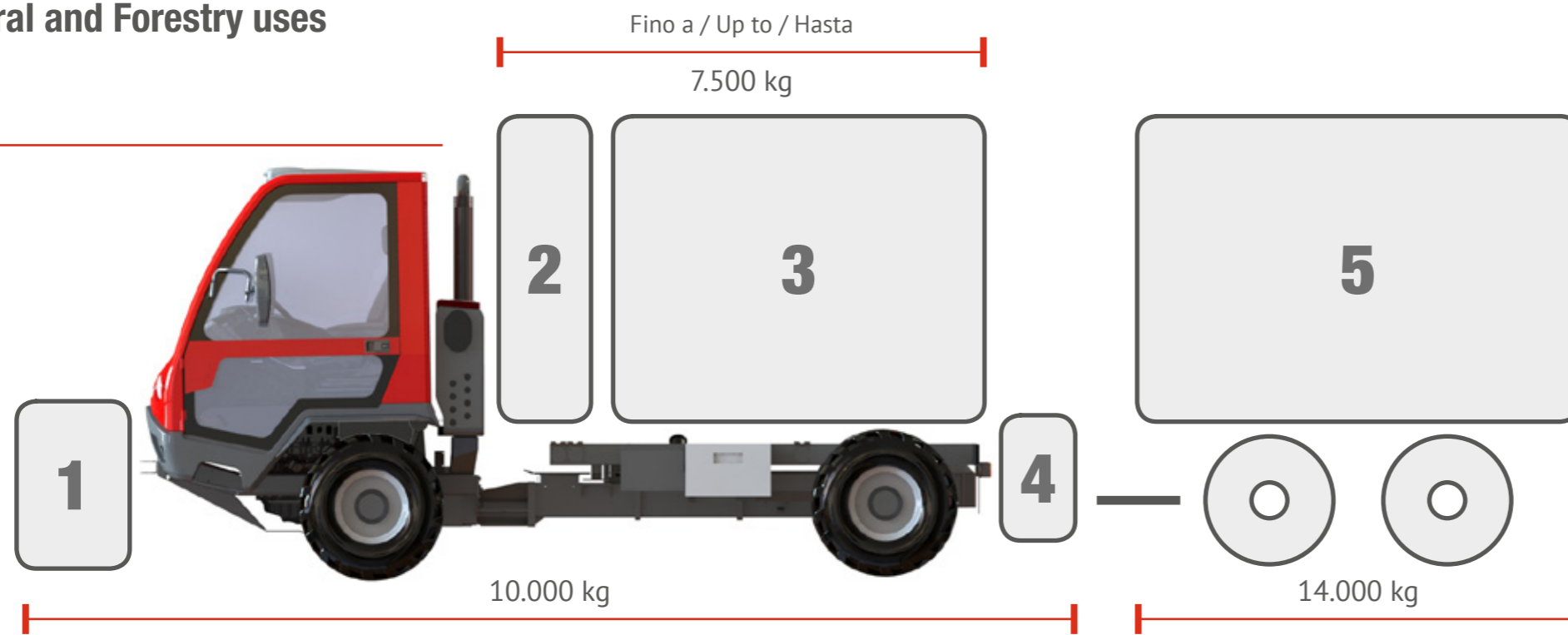

1

Front winch, shredder, front arm-shredders, ...

C..

2

Autocaricante, spandiletame, botte, pinza forestale, pianale forestale, gru, cassone ribaltabile trilaterale, modulo scarrabile con gancio idraulico, ...

3

Hay self-loading wagon, manure spreader, tank, forestry grapple, forestry loading platform, crane, 3-way hydraulic dumping box, hooklift, ...

Carro autocargador de heno, esparcidor de estiércol, tanque, pinza forestal, plataforma de carga forestal, grúa, caja de carga basculante trilateral, hooklift (sistema de levantamiento con gancho), ...

4

Gru posteriore, pinza posteriore, verricello forestale, trincia, rimorchio fino a 14.000 kg, bio-trituratore, ...

5

Rear crane, rear grapple, forestry winch, shredder, trailer up to 14.000 kg, bio-shredder, ...

Grúa trasera, pinza trasera, cabrestante forestal, trituradora, remolque hasta 14.000 kg, bio-trituradora, ...



Municipale e industriale Municipal and industrial Municipal e industriale

Features of CARON Transporters, such as reliability and flexibility, are really appreciated by municipal and industrial operators who use the vehicles for winter and summer maintenance services, material handling on construction sites or municipal warehouses and special uses. The universal chassis, the hydraulic plant with levers or joystick and the front fixing plate allow the assembly of several equipment according to the needs of the customer, who can carry out a wide range of services with only one vehicle.



Municipal and industrial uses

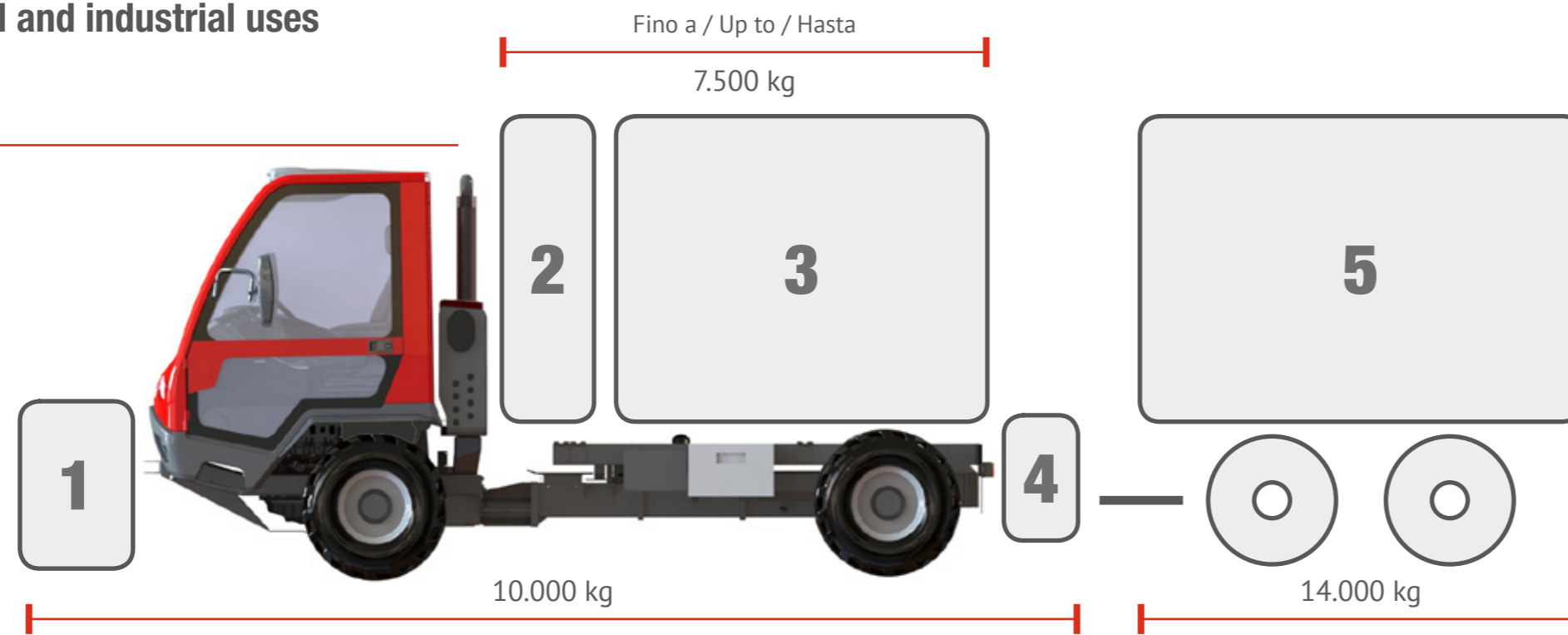

1 Lama / vomere sgombraneve, spazzatrice, braccio trincia anteriore, ...
Snowplough, V-snowplough, sweeper, front shredder, ...
Pala quitanieves, V-pala quitanieves, barredora, trituradora frontal, ...

2 Gru, braccio trincia centrale, spargi sale/sabbia, cassone ribaltabile trilaterale, modulo antincendio, piattaforma aerea, modulo scarrabile con gancio idraulico, allestimenti spurghi, ...

3 Crane, central-arm shredder, salt/sand spreader, 3-way hydraulic dumping box, fire-extinguishing equipment, aerial platform, hooklift, fitting for clean-out service, ...

Grúa, brazo triturador central, esparcidor de sal/arena, caja de carga basculante trilateral, equipo de extinción incendios, plataforma aérea, hooklift (sistema de levantamiento con gancho), instalación para servicios de purga, ...

4 Gru posteriore, rimorchio fino a 14.000 kg, spandi sale/sabbia trainato/sponda, ...

5 Rear crane, trailer up to 14,000 kg, rear salt/sand spreader, ...

Grúa trasera, remolque hasta 14.000 kg, esparcidor de sal/arena trasero, ...





Cabina Cab Cabina

The cab relies on elevated structural resistance and it is approved as roll-over protection system. The wide glazing surfaces ensure complete visibility during work. During the project stage, particular attention was paid to the driving position to reach high comfort for the operator both on road and off-road travels. All controls and levels are placed with the greatest ergonomics and the new digital touch screen display provides all the information for the proper use of the vehicle.





Anatomically shaped seats with a wide adjustment's possibility of the cushion, back and of the suspensions



P The column steering wheel can be manually adjusted (height and inclination)



I Adjustable heating system of the cab. Upon request, air conditioning system



Radio DAB with MP3 Reader and USB inlet. Audio system with two speakers



Storage compartment with door on the passenger side



Stainless steel toolbox placed under the loading platform



~ Cab top with integrated additional lights



Sliding window on the rear side of the cab

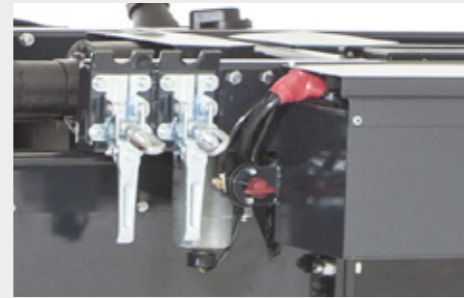

Battery master-switch for the rest period



The new dumping system of the cab allows an easier and faster maintenance. Thanks to a hydraulic piston, the cab can be manually dumped in a few seconds without tools.



The driving position has been carefully developed to reach high comfort and visibility. The wide adjustments of the seats and of the steering column allow the operator to find the perfect driving position at any time.



The new 7" digital touch screen display provides all the information for the proper use and maintenance of the vehicle.

The display's section dedicated to the hydraulic distributor views the control movements, the operating of the relevant electro-valves and the effect of the elements.



The display provides the operator with further useful information, such as reminders about maintenance operations, fuel consumption, information about engine and suspension system. Available also the pairing with the rear wireless camera.



The highest efficiency for any kind of use

Thanks to its remarkable features and to the new chassis equipped with CHS System, this CARON series has become the reference point of the category. The new hydro-pneumatic independent double wishbone suspensions, with automatic level adjustment and suspension lock combine the best off-roads features with an excellent driving on road and allow the transport of any load on every kind of ground.

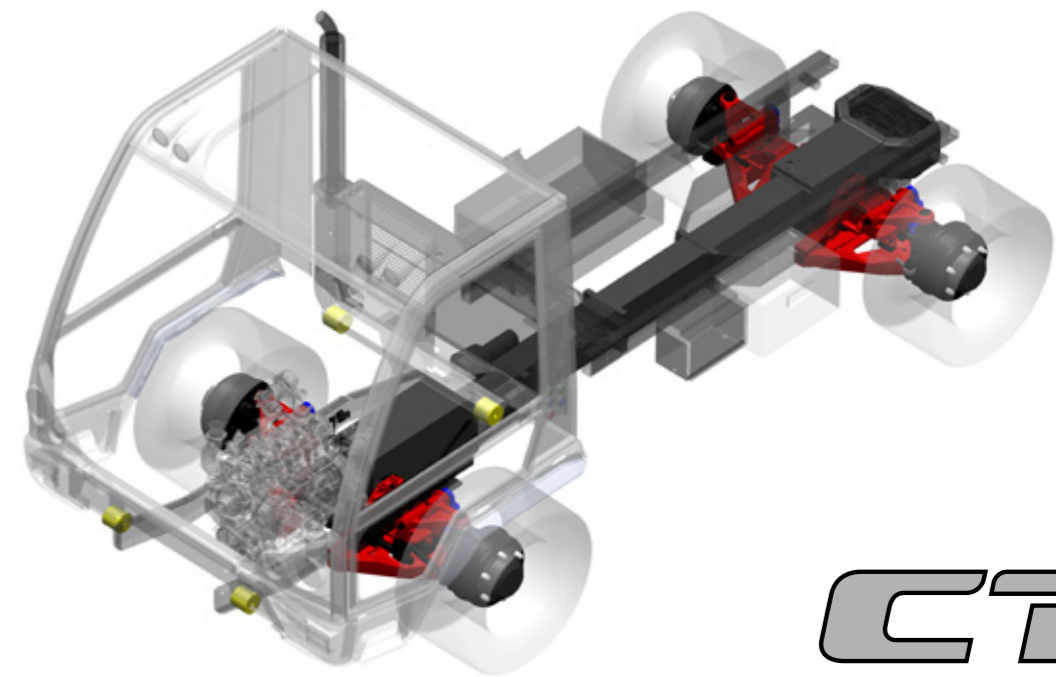

60
km/h

50
km/h

40
km/h

CTS

An innovative vehicle for the most demanding operators

Series CTA matches the dynamic qualities of Series CTS with the efficiency of Series CT. The CHS suspension system on the front axle ensures excellent driving comfort to the operator. Rear axle is rigid.

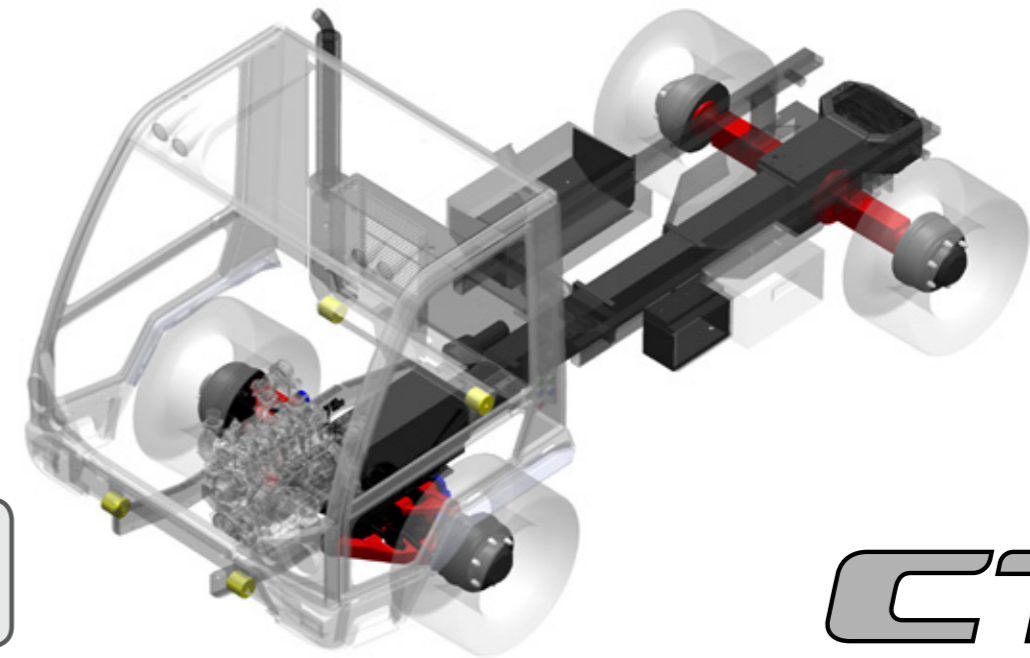

50
km/h

40
km/h

CTA

The highest loading capacity of the category

Compared to the other models, the configuration with rigid axles of the Series CT allows weights reduction with a consequent higher loading capacity. The cab, which lies on shock absorbers and oil silent-blocs, ensures comfort while driving on road.

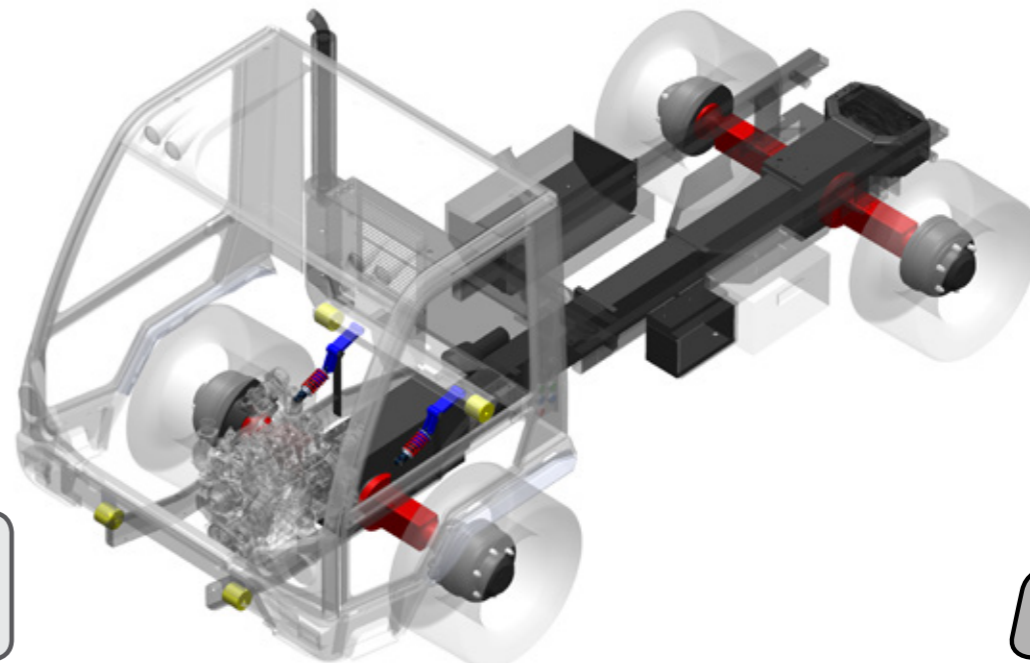

40
km/h

CT

CHS SYSTEM

Caron Hydropneumatic Suspension



FEATURES

- Independent double wishbone suspension
- Suspension range 90 mm
- Hydropneumatic spring system
- Electronic roll control
- Automatic level adjustment according to load changing
- Suspension lock
- Central joint in the chassis
- Final planetary reduction gears
- Front axle load capacity 5000 kg
- Rear axle load capacity 6500 kg

ADVANTAGES

- Better handling
- Improved traction
- Greater driving comfort
- Higher working speed
- Remarkable loading capacity
- Load stabilisation
- Low centre of gravity
- Safety on slopes
- Less tyres wear

Top versatility and productivity: the possibility to manage the suspension system enables an optimal use on road, on all-terrain and with overhanging additional equipment.

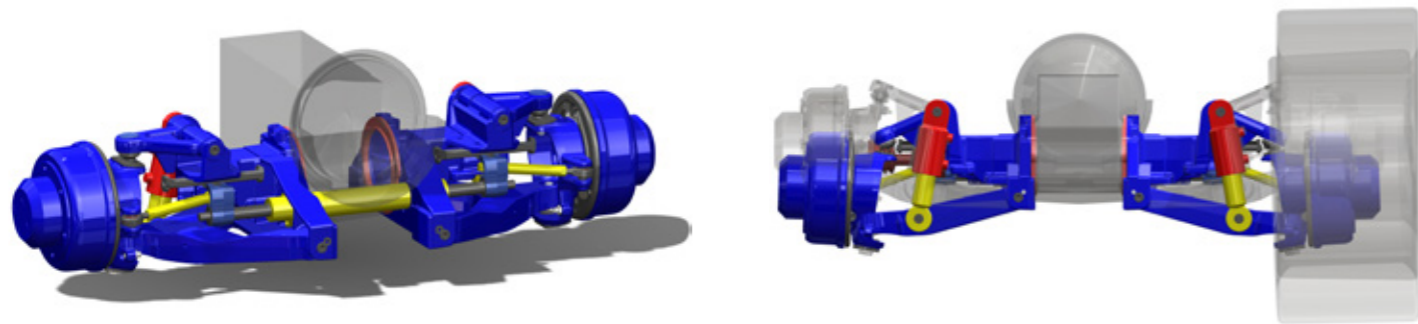

Differently from the single arm suspensions, in the CHS system with independent double wishbone suspension each wheel works perpendicular to the ground under every condition. In this way, tyres always work correctly with more efficiency, less wear but with better stability, traction, handling and driving comfort.

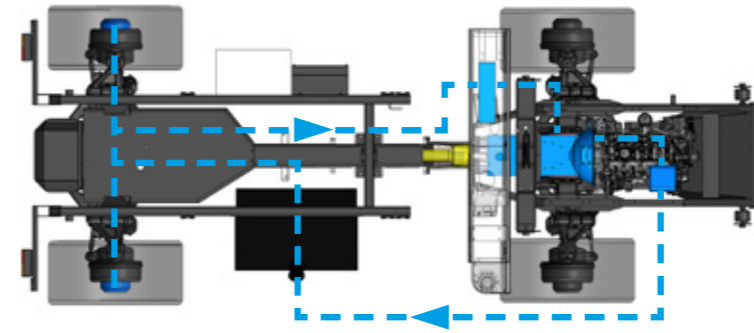

Hydraulic cooling plant - Oil cooling circle for the gearbox and planetary reduction gears during heavy and continuous works.

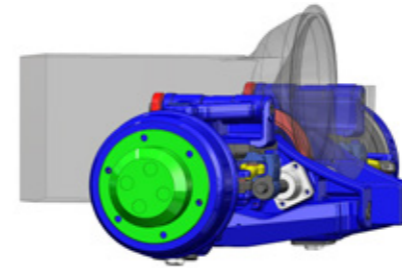

Spheroidal cast iron axles with final planetary reduction gears



The central joint in the chassis ensures constant grip of the four wheels also on the most uneven surfaces

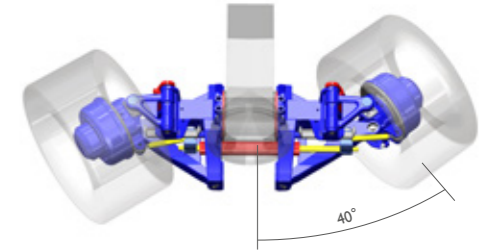

A small turning radius thanks to the wide steering angle of over 40°

Modalità Cerchio
Circle Steering Mode
Modalidad de Dirección círculo



Modalità Granchio
Crab Steering Mode
Modalidad de Dirección Cangrejo

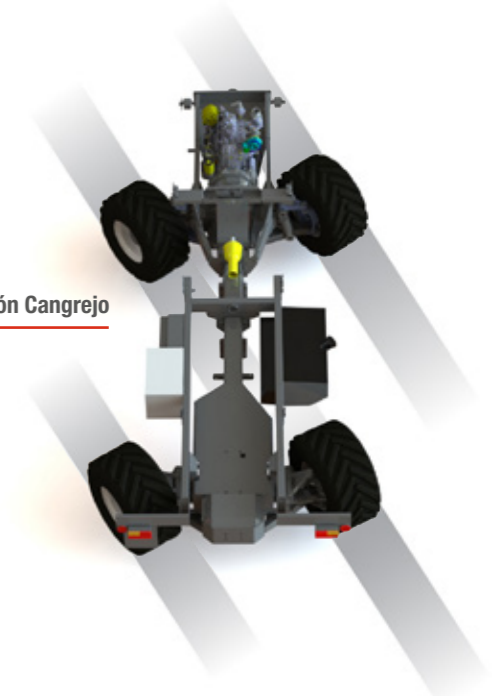

With the 4-wheel steering version, the transporter reaches an exceptional manoeuvrability level. By changing from Standard Steering Mode to the "Circle" Steering Mode the turning radius significantly reduces. In the "Crab" Steering Mode, the driver can perform special operations or exceed cross-cutting slopes with the possibility to lock the rear steering at the most proper angle. All operations can be carried out under utmost practicality thanks to a selector that allows the user to shift from a mode to another one at any time. All the relevant information shown on the display together with audible warnings make the system really easy and safe to operate.

Braking system

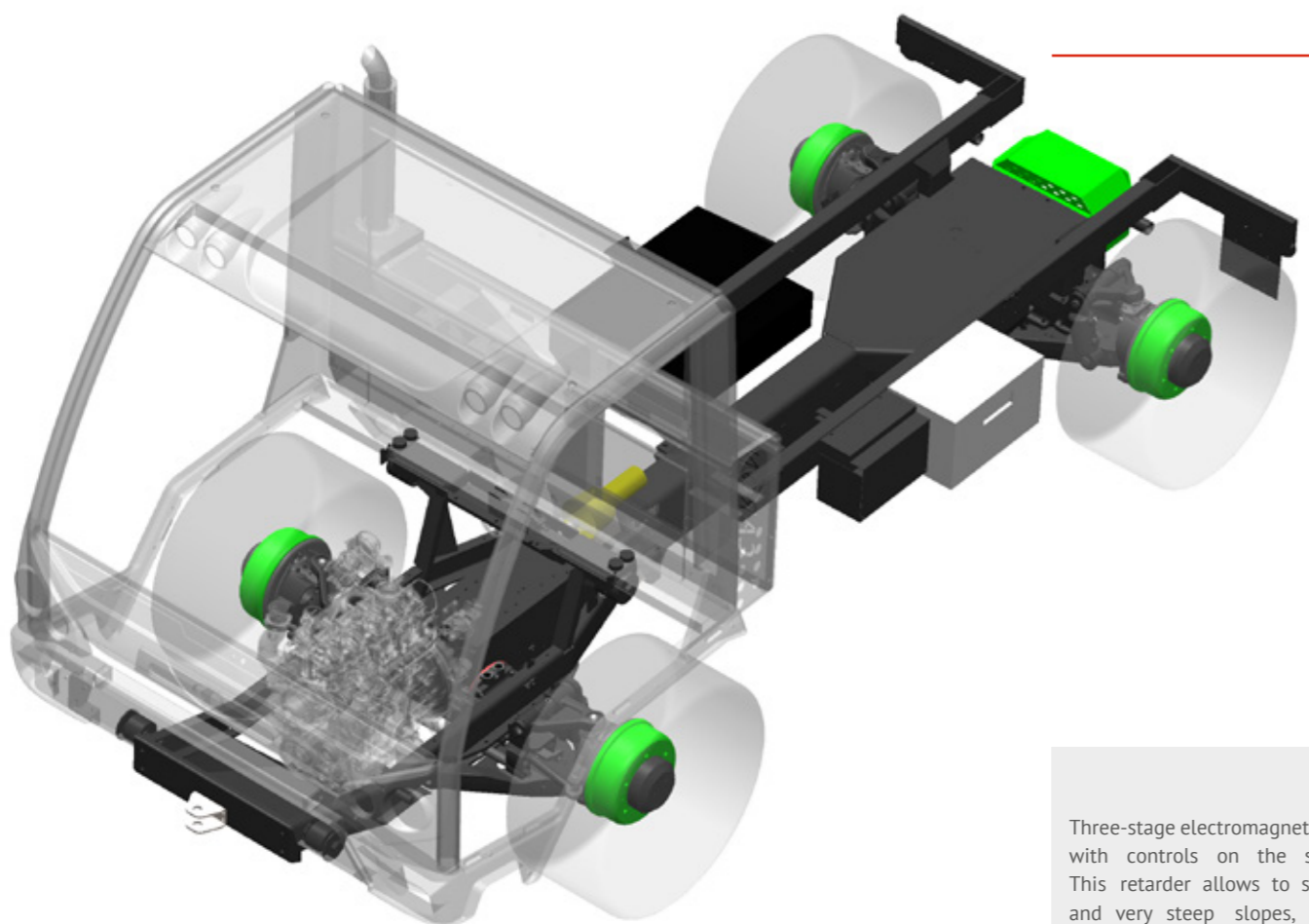

Parking spring brake on rear wheels acting with hand lever and hydraulic transmission.



Three-stage electromagnetic brake retarder with controls on the steering wheel. This retarder allows to safely face long and very steep slopes, without using the braking system and with no wear.

Dual hydraulic circuit braking system on 4 wheels, with floating jaws and self adjusting brakes, Ø 315 mm, with Servobrake. Thanks to this braking system, the vehicle safely stops within a reduced space on any kind of ground, even muddy or dusty. The research and study during the project stage has led to the development of a vehicle with very high loading capacity and total weight of 10,000 kg, unique in its category.



PTO on rear axle with electro-hydraulic control, with 2-speeds (540-1000 rpm/min), low and/or high outlet, with independent hydraulic clutch and/or synchronized with the feed.



0/1000 giri/min.), con comando elettro-idraulico Central PTO with 2-speeds (540-1000 rpm/min) with independent hydraulic clutch and electro-hydraulic control



Rear 3-point linkage, max lifting torque 800 kgm (possibility to increase it). Supplied with kit of supporting feet for the tipping body

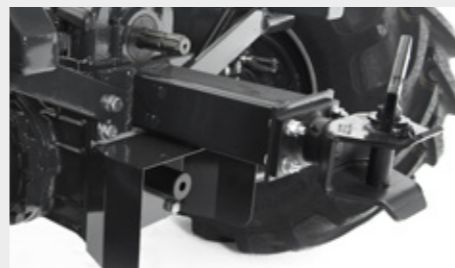

Approved rear drawbar hitch for braked trailers up to 6,000 kg. Upon request: approved drawbar hitch and brake plant for braked trailers up to 14,000 kg



Hydraulic versions w/distributors from 3 to 5 elements, outlets in front of/rear cab, controls through joystick. Increased version also available: independent oil tank and pump with 75 l/min (200 bars) max flow



Hydraulic version with front outlets to apply equipment on the fixing plate



102 litres plastic tank with metal protection support



Dual wheels 7.50x16 with quick connecting hooks on front and/or rear axle



Dual wheels 280/70 R18 or 7.50x18 with quick connecting hooks on rear axle



Hydraulic 3-way dumping body, with reinforced loading platform, tubular sides and protection grid for the cab. Mounted on removable chassis and provided with kit of supporting feet. Standard sizes: 280x190x40 cm (Wheelbase 2600 mm) or 316x190x40 cm (Wheelbases 2800-3000 mm)

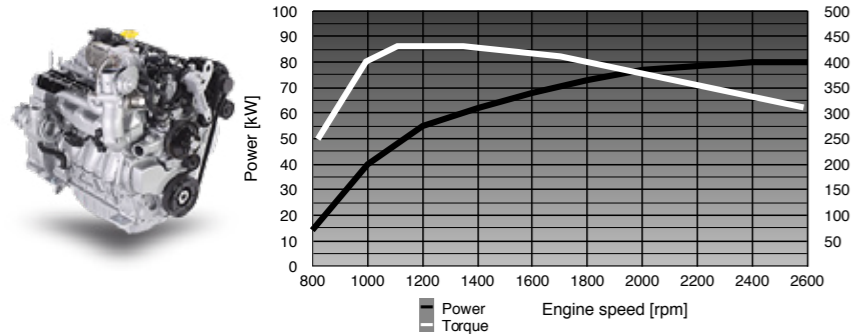

CTS - CTA - CT 110 EU6

Motore - Engine - Motor	VM R754EU6
n° Cil. / cm1	4 Common Rail / 2970
Potenza - Power - Potencia	80 kW (109 CV) @ 2600 rpm
Coppia - Torque - Par	420 Nm @ 1100 rpm
Emission certificate	EURO 6

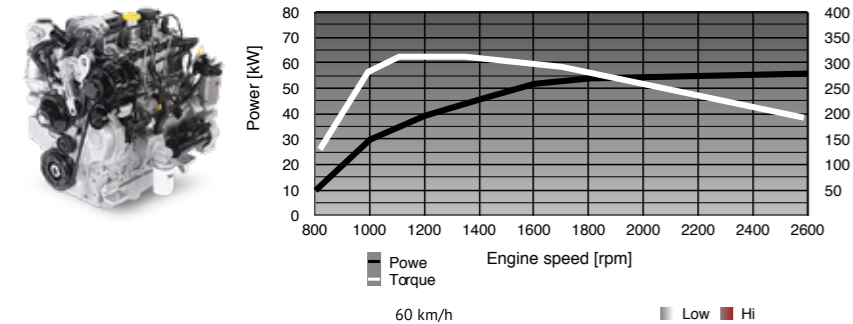

CTS - CTA - CT 80

Motore - Engine - Motor	VM R754ISE4
n° Cil. / cm1	4 Common Rail / 2970
Potenza - Power - Potencia	55 kW (75 CV) @ 2600 rpm
Coppia - Torque - Par	310 Nm @ 1100 rpm
Emission certificate	Stage 3B

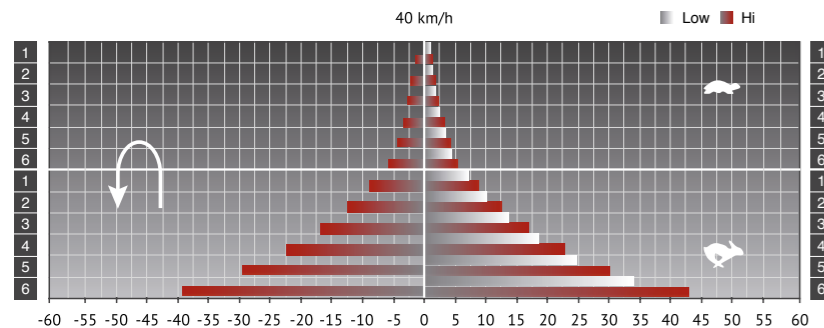
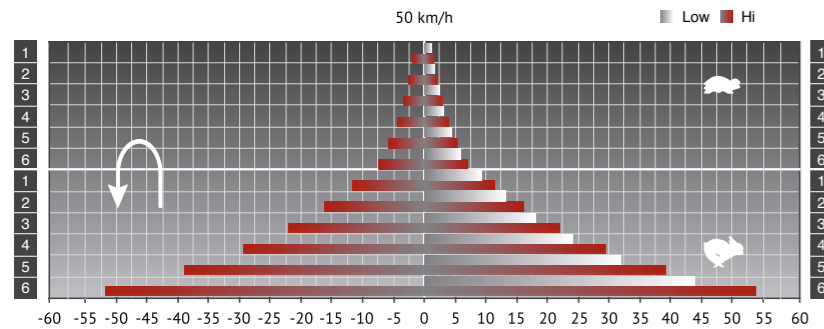
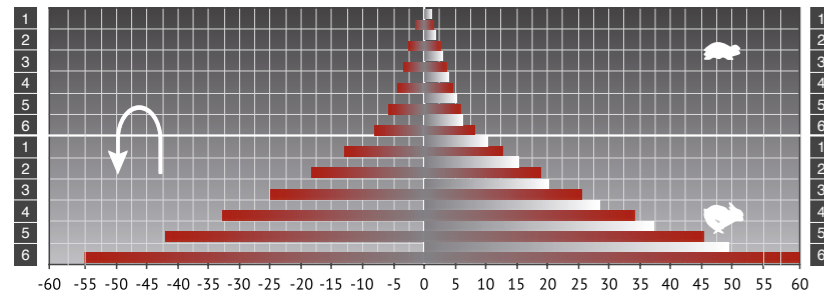

CARON 6-speed gearbox with synchronized reduction gear and Hi-Low has 36 speeds (24 forward + 12 reverse). According to the choice, the max speed can be 40, 50 or 60 km/h with a speed range starting from 0.4 km/h. This practical and innovative layout ensures to find always the right speed to get the most appropriate power during any job.

E

PNEUMATICI
TYRES
NEUMATICOS



425/55 R17



440/50 R17



15.5/55 R18



265/70 R19,5
285/70 R19,5

SERIE - SERIES - SERIE	CTS	CTA	CT
ASSALE ANTERIORE FRONT AXLE EJE DELANTERO	Sospensioni idropneumatiche Hydropneumatic suspensions Suspensiones hidroneumáticas	Sospensioni idropneumatiche Hydropneumatic suspensions Suspensiones hidroneumáticas	Assale rigido Rigid axle Eje rígido
ASSALE POSTERIORE REAR AXLE EJE TRASERO	Sospensioni idropneumatiche Hydropneumatic suspensions Suspensiones hidroneumáticas	Assale rigido Rigid axle Eje rígido	Assale rigido Rigid axle Eje rígido
TELAIO CHASSIS CHASIS	Snodo lineare centrale incorporato / Central joint / Articulación central		
STERZO STEERING DIRECCIÓN	Idrraulico sulle ruote anteriori. Optional: 4 ruote sterzanti Hydraulic on the front wheels. Option: 4-wheel steering Hidráulica en las ruedas delanteras. Opción: 4 ruedas directrices	Idrraulico sulle ruote anteriori Hydraulic on the front wheels Hidráulica en las ruedas delanteras	
FRENI SERVIZIO BRAKING SYSTEM SISTEMA DE FRENADO	Idraulici a doppio circuito sulle 4 ruote con masse flottanti autoregistranti Ø 315 mm con servofreno. Optional: freno rallentatore elettromagnetico (retarder) / Dual hydraulic circuit braking system on 4 wheels, with floating jaws and self adjusting brakes, Ø 315 mm, with Servobrake. Option: Magnetic brake retarder / Frenos de doble circuito hidráulico en las 4 ruedas, con masas flotantes y autoregistrables, Ø 315 mm con servofreno. Opción: Freno retardador electromagnético (Retarder)		
FRENI STAZIONAMENTO PARKING BRAKE FRENO ESTACIONAMIENTO	A molla agente sulle ruote posteriori con comando idraulico e modulatore progressivo / Parking spring brake on rear wheels acting with hand lever and hydraulic transmission / Freno de estacionamiento de muelles en las ruedas traseras con mando hidráulico y modulador progressivo		
CAMBIO GEARBOX CAMBIO	A 6 marce sincronizzato a 36 velocità (24+12) con inversore e Hi-Low sincronizzati 36 speeds-synchronized gearbox (24fwd/12rev) with synchronized Hi-Low and Inverter Sincronizado de 36 velocidades (24 adelante+12 atrás), con Hi-Low e Inversor sincronizados		
VEL. MAX. (km/h) MAX SPEED MAX VELOCIDAD	40 Km/h 50 Km/h (mod. 80) 60 Km/h (mod. 110.EU6)	40 Km/h 50 Km/h (mod. 80)	40 Km/h
TRAZIONE DRIVE TRACCIÓN	4 ruote motrici con disinnesto elettro-idraulico della trazione anteriore. Assali con riduttori epicicloidali finali 4x4 wheel drive with electro-hydraulic disengagement of front drive. Axles with final planetary reduction gears Cuatro ruedas motrices con desembrague electrohidráulico de la tracción delantera. Ejes con reductores epicicloidales finales		
DIFFERENZIALI DIFFERENTIAL DIFERENCIAL	Anteriore e posteriore con bloccaggio elettroidraulico Front and rear with electro-hydraulic lock Delantero y trasero con bloqueo electrohidráulico		
MASSA TOTALE TOTAL WEIGHT PESO TOTAL	10.000 kg		
MASSA A VUOTO UNLADEN WEIGHT PESO EN VACIO	3.300 kg (senza cassone / without body / sin caja)	3.100 kg (senza cassone / without body / sin caja)	2.800 kg (senza cassone / without body / sin caja)
RIMORCHIABILE TOWING WEIGHT PESO REMORCABLE	fino a / up to / hasta 14.000 kg (9.000 kg Mod. 80)		
PRESA DI FORZA POWER TAKE OFF TOMA DE FUERZA	PTO centrale e/o posteriore con frizione idraulica indipendente a 540/1000 giri/min Central and/or rear PTO with independent hydraulic clutch and 2-speeds (540-1000 rpm/min) Toma de fuerza centrale y/o trasera con embrague hidráulico independiente y dos velocidades (540/1000 rpm/min)		
IMPIANTO IDRAULICO HYDRAULIC PLANT SISTEMA HIDRÁULICO	Varianti idrauliche con innesti rapidi davanti e/o dietro cabina, distributore idraulico a 3, 4, 5 elementi con comando tramite joystick; Pompa con portata max 40lt/min a 170 bar / Hydraulic versions with outlets in front of/rear cab, distributors of 3,4,5 elements through joystick; Pump with max flow of 40 l/min (170 bars) / Versiones hidráulicas con tomas detrás/delante la cabina, distribuidores de 3, 4, 5 elementos, mando por joystick; Bomba de caudal max 40 l/min a 170 bar.		
OPTIONALS	Variante idraulica potenziata con pompa portata max 75 lt/min a 200 bar e serbatoio olio indipendente Increased hydraulic version with independent oil tank and pump with max flow of 75 l/min at 200 bars Versión hidráulica reforzada con tanque aceite independiente y bomba de caudal max 75 lt/min a 200 bar		
	Gancio traino omologato; Sollevatore posteriore con attacco a tre punti; Piastra porta-attrezzi anteriore Approved drawbar hitch; Rear 3-point linkage; Front fixing plate for equipment Enganche remolque homologado; Aparato elevador trasero de tres puntos; Placa de enganche delantera para equipos		

DIMENSIONI - DIMENSIONS - DIMENSIONES (cm)						
Passo / Wheelbase/ Paso	A	B	C	D	E	F
2600	132	260	72	464	194-214	235-240
2800	132	280	72	484	194-214	235-240
3000	132	300	72	504	194-214	235-240

