

◇ 1.1x1.1
SF1100

■ 1.21x1.21
SH1210

	◇ Hg (m)	■ Hg (m)
FEM	○	○
CATR	17.4	36.7
CAF	28.7	41.7
TEF	28.5	41.5
TRF	28.5	41.5



▤ CATR
▤ CATC

CAF

TEF

TRF

PRT-TR

PRT

Power Control

ASsys

ACsys

CE

FEM 1.001 - A4
EN 14439 - C25 - D25

Torre/Reazioni – Masts/Reactions – Mat/Réactions – Maste/Eckdrücke – Măstil/Reacciones – Tramo/Reacções

SF1100 FEM

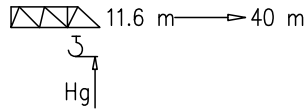

○ Hg=Ht-1 m

3	ST058	1/1
2	BA058	2/1
1	B0058	2/2

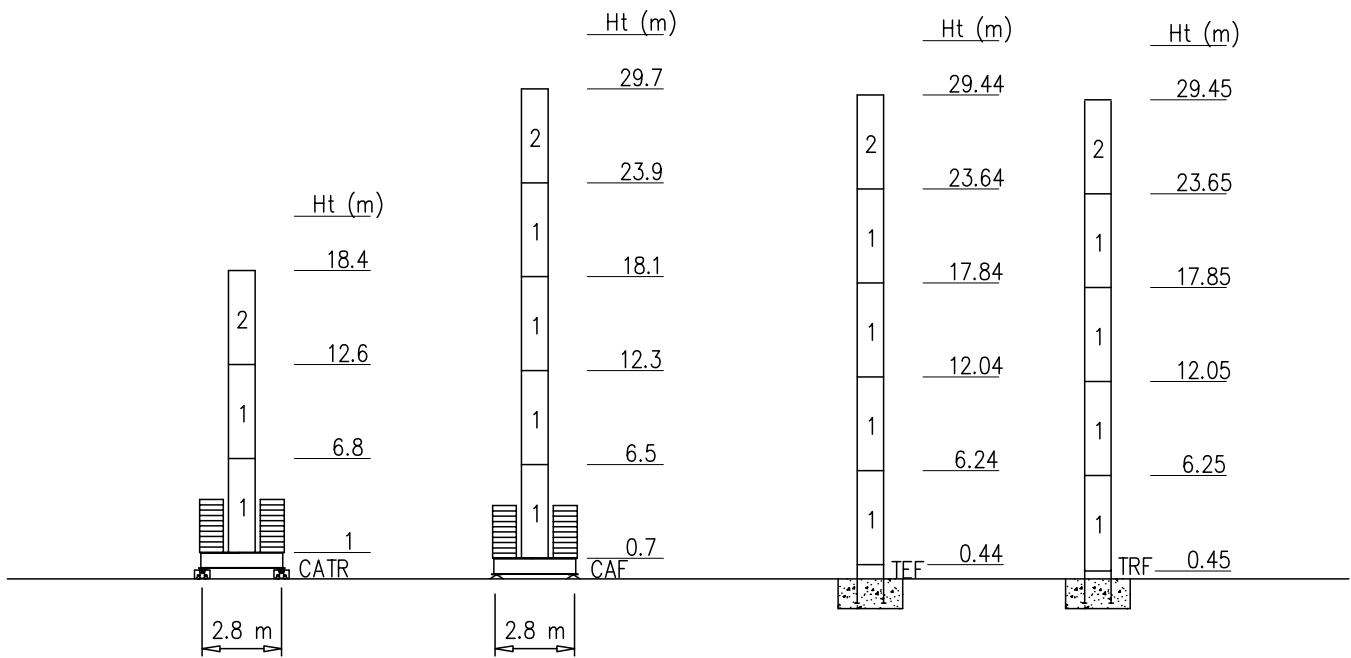

Peso zavorra – Ballast weight – Poids du lest – Ballastgewicht – Peso de lastre

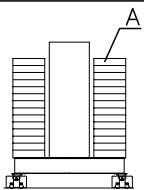

SF1100	
H-CATR (m)	18.4
FEM (t)	26.4
n°	12xA

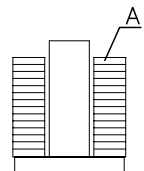
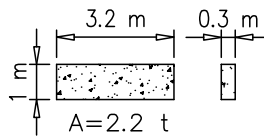

SF1100			
H-CAF (m)	12.3	23.9	29.7
FEM (t)	22	26.4	30.8
n°	10xA	12xA	14xA

Torre/Reazioni – Masts/Reactions – Mat/Réactions – Maste/Eckdrücke – Mästil/Reacciones – Tramo/Reacções

SH1210 FEM

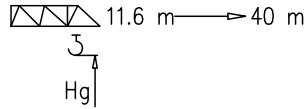

○ Hg=Ht-1 m

4	B0120	2/2
3	B0060	2/2
2	ST030	2/2
1	ST060	2/2

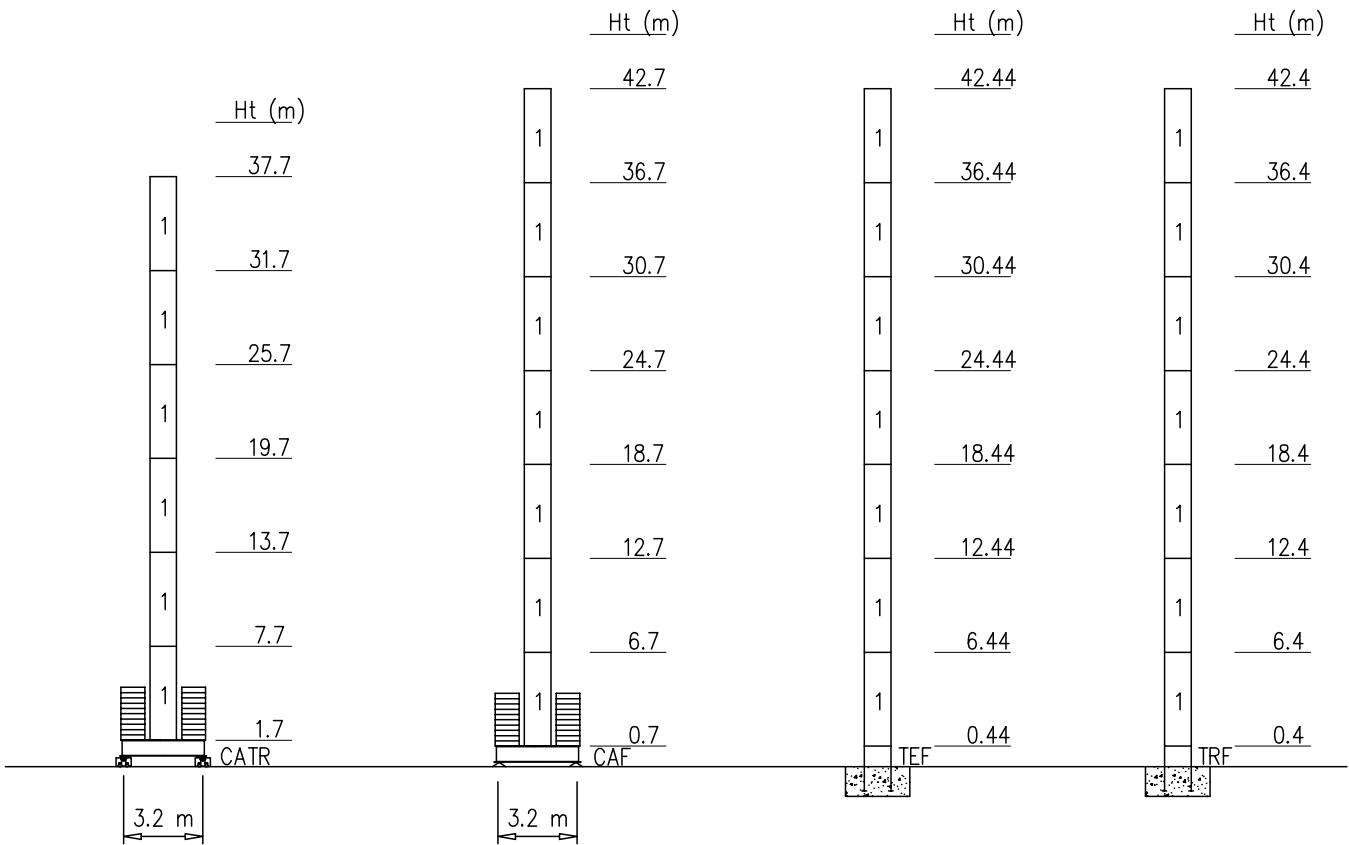

Peso zavorra – Ballast weight – Poids du lest – Ballastgewicht – Peso de lastre

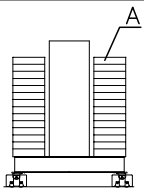

SH1210	
H-CATR (m)	37.7
FEM (t)	54
n°	18xA

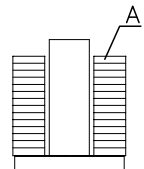
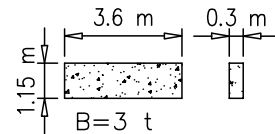

SH1210				
H-CAF32 (m)	18.7	30.7	36.7	42.7
FEM (t)	18	30	54	78
n°	6xB	10xB	18xB	26xB





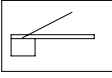
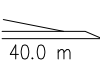
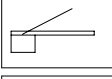
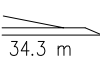
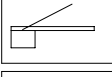
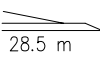
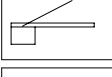
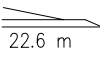
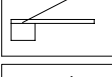
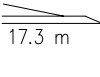
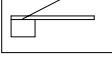
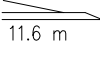





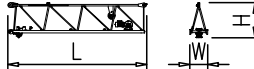
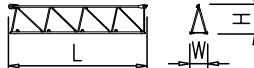

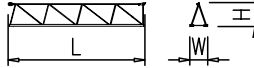
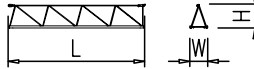

Curve di carico – Courbes de charges – Load diagrams – LastKurven – Curvas de cargas

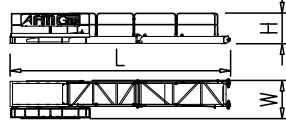
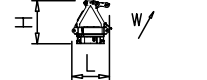
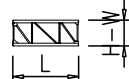
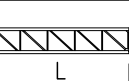
Pmax 2400 kg

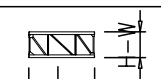
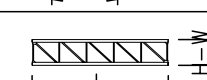

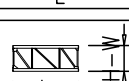
	7680 kg		40.0 m	2	18.5	22.6	28.5	34.3	40.0	m
				2400	2400	1920	1500	1200	1000	kg
	6600 kg		34.3 m	2	20.0	22.6	28.5	34.3		m
				2400	2400	2180	1680	1350		kg
	6030 kg		28.5 m	2		22.6	28.5			m
				2400		2400	1900			kg
	4950 kg		22.6 m	2		22.6				m
				2400		2400				kg
	4380 kg		17.3 m	2		17.3				m
				2400		2400				kg
	3300 kg		11.6 m	2		11.6				m
				2400		2400				kg

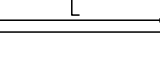

PESI E INGOMBRI – PACKING LIST – LISTE DE COLISAGE – GEWICHT UND ABMESSUNGEN

Denominazione Description	Disegno Draw	Pezzi Pieces	Dimensioni-Dimensions (mm)			Peso-Weight (kg)		
			L	W	H	Unit	Total	
Elemento di braccio Jib element Elément deèche Elemento de flecha	n°7 	1	5910	800	1500	900	–	
	n°6 	1	5910	760	1270	590	–	
	n°5 	1	5890	760	1260	460	–	
	n°4 	1	5870	760	1050	390	–	
	n°3 	1	5850	760	1040	285	–	
	n°2 	1	5830	760	1020	205	–	
	n°1 	1	5820	760	1020	180	–	
	Punta braccio 	1	410	760	690	45	–	
Contorbraccio completo Complete counterjib Contreflèche complète Contraflecha completa		1	9400	1650	1310	2250	–	
Gruppo girevole Slewing group Table tournante Grupo giratorio		SF1100	1	1600	1350	1830	2050	–
		SH1210	1	1600	1350	1830	2200	–
Elemento di torre Mast element Elément de mature Elemento de torre	ST028 	SF1100	–	2800	1100	1100	550	–
	ST030 	SH1210	–	3000	1210	1210	840	–
	ST058 	SF1100	–	5800	1100	1100	1010	–
	ST060 	SH1210	–	6000	1210	1210	1490	–
	ST116 	SF1100	–	11600	1100	1100	1900	–
	ST120 	SH1210	–	12000	1210	1210	3000	–
	B0028 	SF1100	–	2800	1100	1100	600	–
	B0030 	SH1210	–	3000	1210	1210	900	–
	B0058 	SF1100	–	5800	1100	1100	1260	–
	B0060 	SH1210	–	6000	1210	1210	2120	–
	B0116 	SF1100	–	11600	1100	1100	2370	–
	B0120 	SH1210	–	12000	1210	1210	3500	–
	BA028	SF1100	–	2800	1100	1100	555	–
	BA030	SH1210	–	3000	1210	1210	870	–
	BA058	SF1100	–	5800	1100	1100	1020	–
	BA060	SH1210	–	–	–	–	–	–
BA116	SF1100	–	11600	1100	1100	2030	–	
BA120	SH1210	–	–	–	–	–	–	

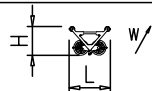
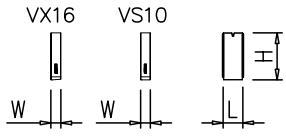
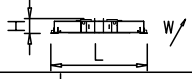
PESI E INGOMBRI – PACKING LIST – LISTE DE COLISAGE – GEWICHT UND ABMESSUNGEN

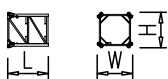
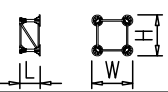
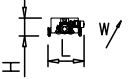
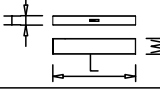
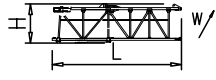
Denominazione Description	Disegno Draw	Pezzi Pieces	Dimensioni–Dimensions (mm)			Peso–Weight (kg)		
			L	W	H	Unit	Total	
Carrello Trolley Chariot Carretilla		1	880	980	650	75	–	
Blocchi contrappeso Counterweight block Contre-poids Bloques de contrapeso		VS10	1	850	420	1300	1080	1080
		VX16	4	850	420	2000	1650	6600
Carro di base Base carriage Chassis de base Cruceta de base		2.8x2.8	1	4100	520	660	1050	1050
		3.2x3.2	1	4670	520	660	1160	1160
		2.8x2.8	2	1900	340	660	480	960
		3.2x3.2	2	2180	340	660	550	1100
Elemento a perdere Disposable frame Chassis a perdre Bastidor desechable		SF1100	1	2315	1100	1100	410	–
		SH1210	1	1990	1210	1210	540	–
Elemento recuperabile Recoverable frame Chassis r�cup�rable Bastidor recuperable		SF1100	1	440	1600	1600	630	–
		SH1210	1	440	1700	1700	660	–
Bogie di traslazione Driven bogie Boggie motoris�e Balanc�n de traslaci�n		4	1160	700	600	700	2800	
Blocco zavorra di base Base ballast block Lest de base Bloque de lastre		2.8x2.8	–	3200	1000	300	2200	–
		3.2x3.2	–	3600	1150	300	3000	–
Corsoio di montaggio Climbing cage Cage de montage Jaula de montaje		1	8300	1600	1500	3000	–	

Montaggio – Montage – Erection – Montage – Montaje – Montagem

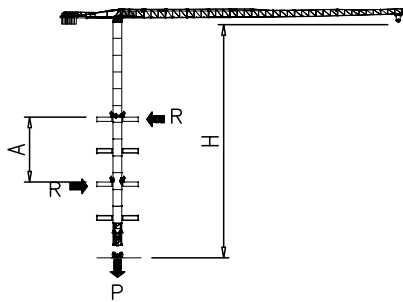

SH1210	H (m)	A (m)
	30.0	Min 9
Apertura passaggio gru Opening for crane passing 		Max 12

* SOPRALZO IDRAULICO – TELESCOPABLE – EXTERNAL CLIMBING – KLETTERKRANE

FEM

	SH1210	SF1100
MAX C	27 m	
B	17 m	
A	19 m	

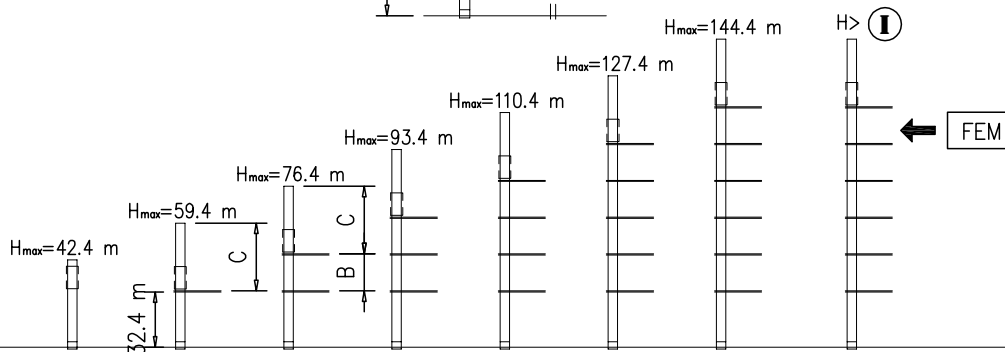
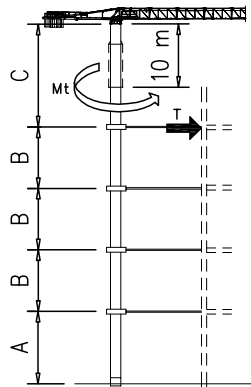

Montaggio – Montage – Erection – Montage – Montaje – Montagem

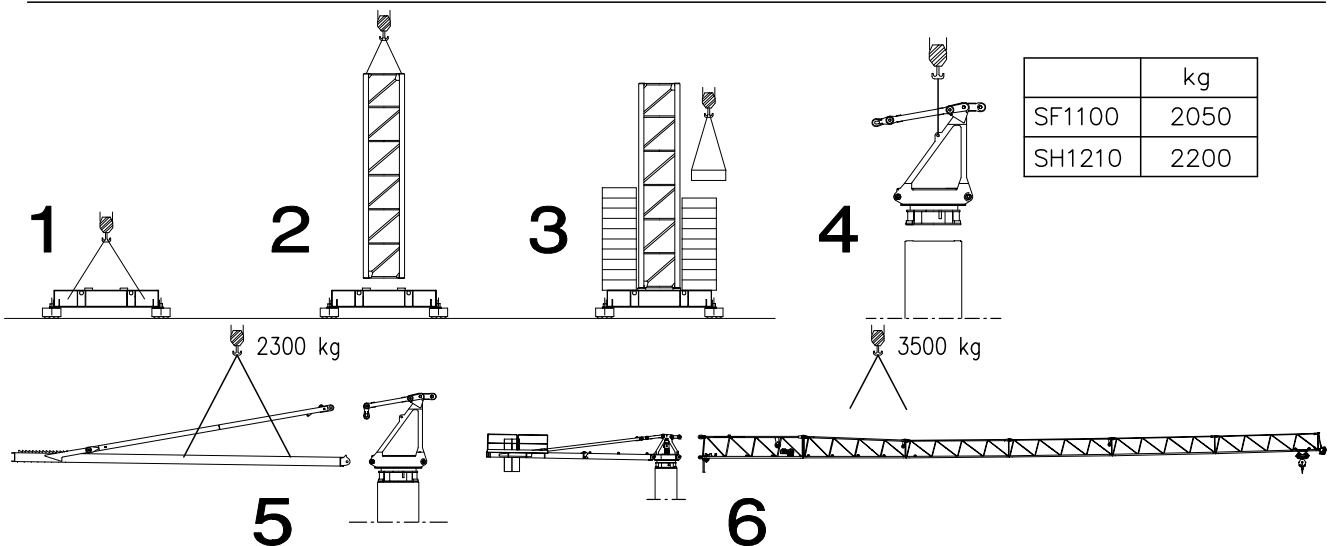

	kg
SF1100	2050
SH1210	2200

Meccanismi – Mechanisms – Mécanismes – Antriebe – Mecanismos

Sollevamento M07.47 Hoisting Levage Heben Elevaciòn Elevaçao							
	m/min	3	16	36	40	47	M07.47
	t	2.4	2.4	1	0.8	0.4	7.5 kW
							18 kVA
							110 m

Carrello Trolleying Distribution Katzfahren Distribuciòn Distribuiçao			0 → 70	m/min	1.1 kW	Potenza elettrica necessaria Puissance électrique nécessaire Necessary electric power Anschlusswert – Potencia
Rotazione Slewing Orientation Schwenken Orientaciòn Rotaçao			0 → 0,7	giri/min tr/min rp/min	4 kW	
Traslazione Travelling Translation Kranfahren Traslaciòn Traslaçao			0 → 18	m/min	3.7 kW	

Rete elettrica – Réseau – Mains supply – Netzstrom – Red – Rede electrica	400V – 50 Hz
	480V – 60 Hz

FEM 1.001 – A4	
EN 14439 – C25 – D25	