

Power Control ASsys ACsys ULTRALIFT

CE FEM 1.001 - A4
EN 14439 - C25 - D25

Torre/Reazioni – Masts/Reactions – Mat/Réactions – Maste/Eckdrücke – Mástil/Reacciones – Tramo/Reacções

SN2050 FEM

○ Hg=Ht-1 m
 □ Hg=Ht-1.8 m

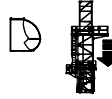
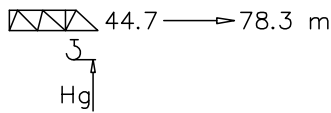

14	BCF052	2/4 M45
13	BAF052	2/4 M42
12	BPF117	4/4 M45-45
11	BNF117	4/4 M45-42
10	BOF117	4/4
9	BOF039	4/4
8	BO039	2/2
7	STR039	2/2
6	SBR117	4/2
5	SBR039	4/2
4	SB117	4/2
3	SB039	4/2
2	ST117	2/2
1	ST039	2/2

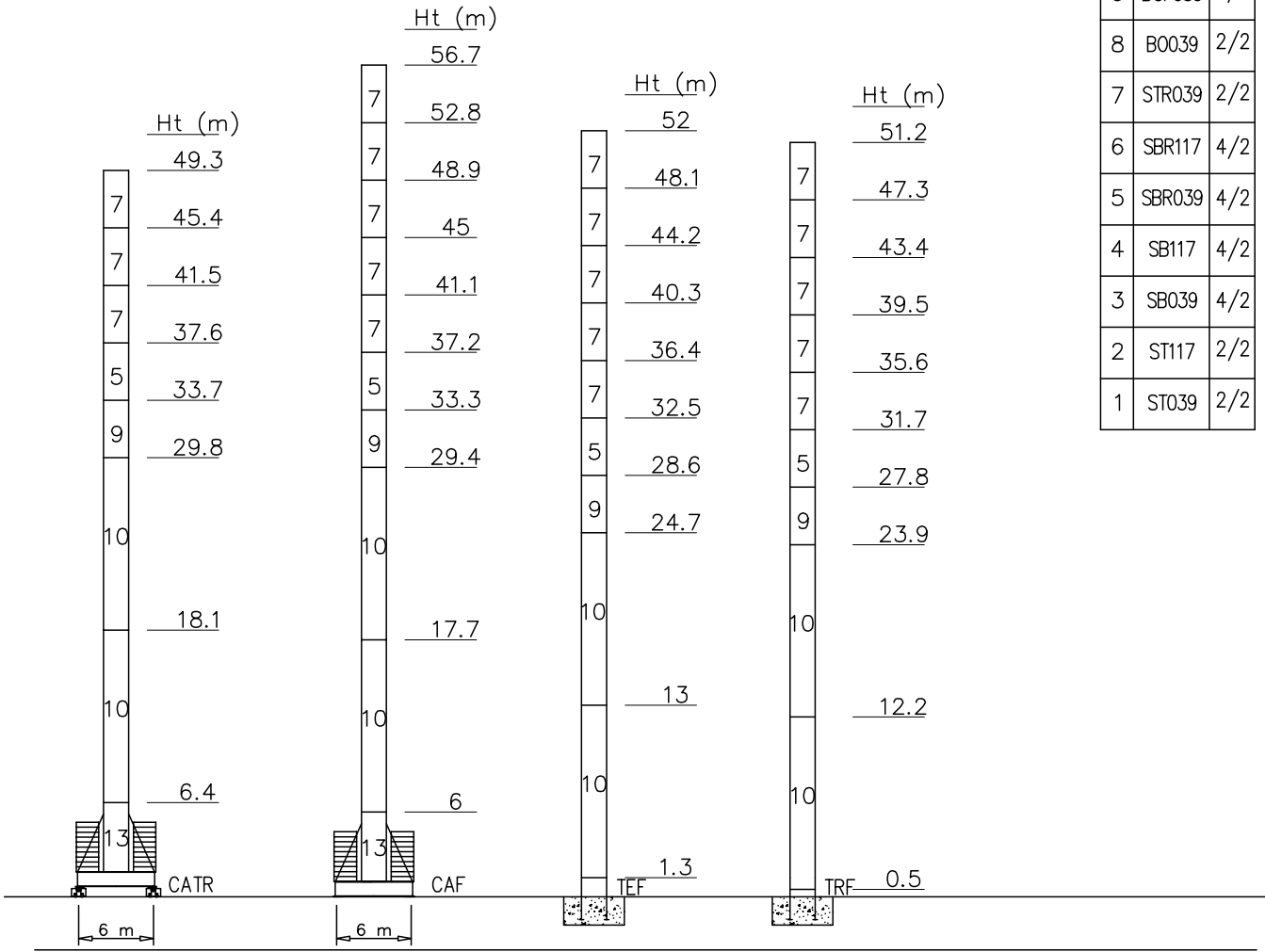

Peso zavorra – Ballast weight – Poids du lest – Ballastgewicht – Peso de lastre

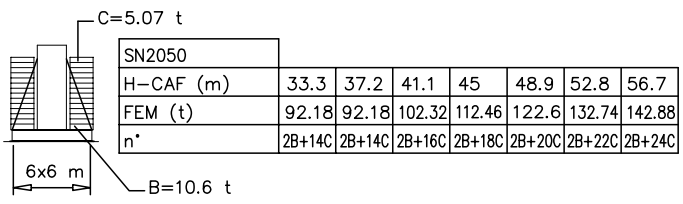
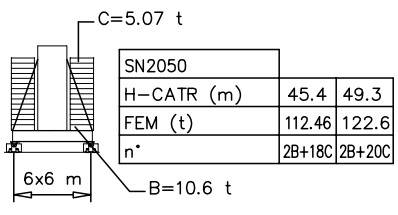

Torre/Reazioni – Masts/Reactions – Mat/Réactions – Maste/Eckdrücke – Mástil/Reacciones – Tramo/Reacções

SN2050 FEM

○ Hg=Ht-1 m
 □ Hg=Ht-1.8 m

44.7 → 78.3 m

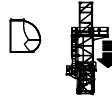

14	BCF052	2/4 M45
13	BAF052	2/4 M42
12	BPF117	4/4 M45-45
11	BNF117	4/4 M45-42
10	BOF117	4/4
9	BOF039	4/4
8	BO039	2/2
7	STR039	2/2
6	SBR117	4/2
5	SBR039	4/2
4	SB117	4/2
3	SB039	4/2
2	ST117	2/2
1	ST039	2/2

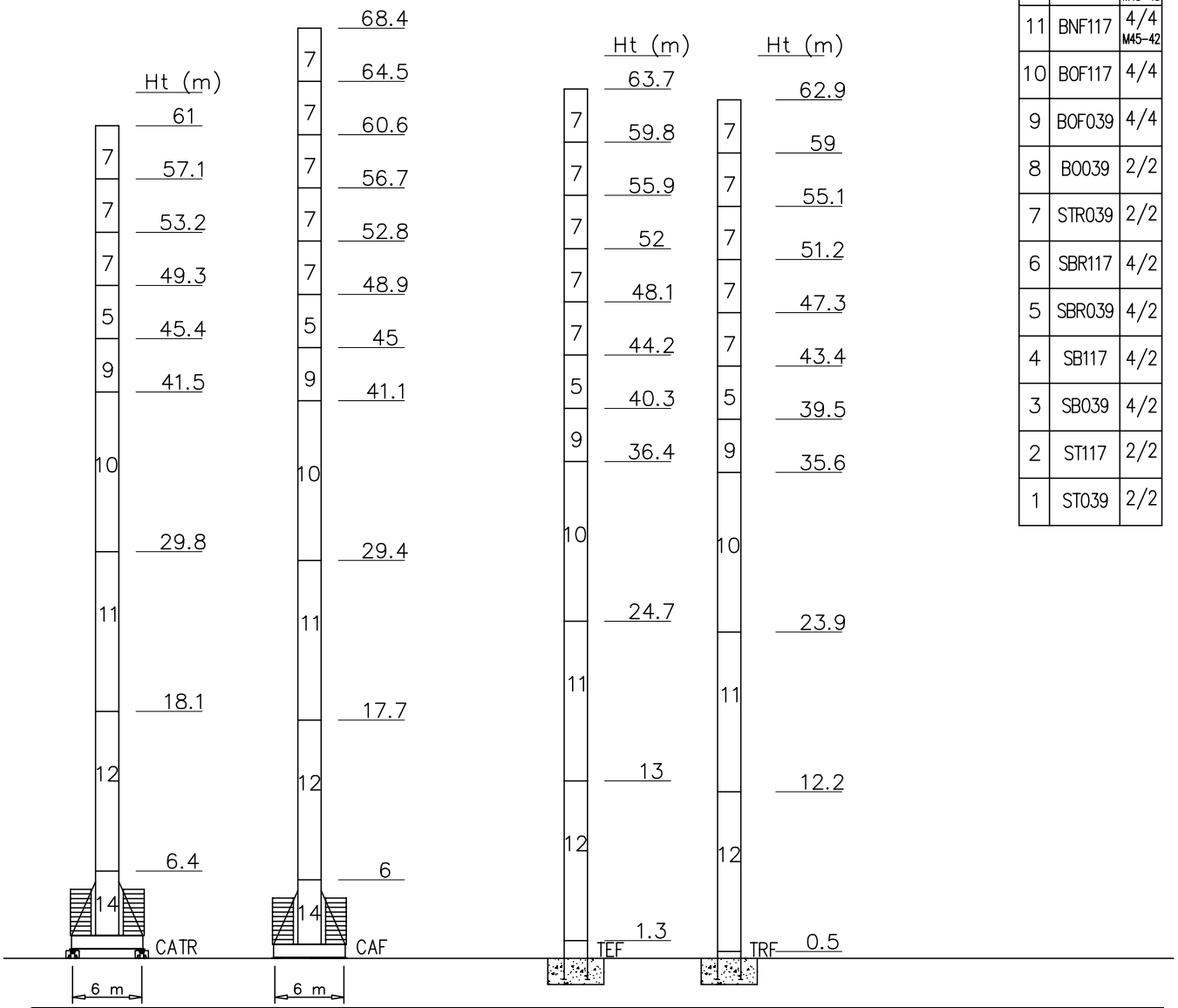

Peso zavorra – Ballast weight – Poids du lest – Ballastgewicht – Peso de lastre

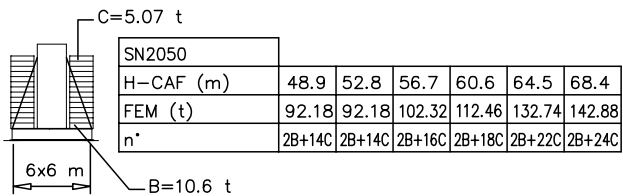
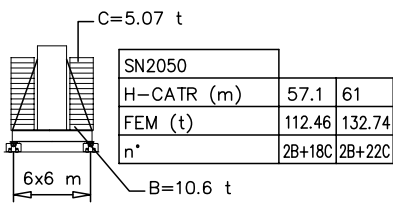

Torre/Reazioni – Masts/Reactions – Mat/Réactions – Maste/Eckdrücke – Măstil/Reacciones – Tramo/Reacções

SN2050 EN14439-C25

44.7 → 78.3 m

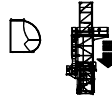

○ Hg=Ht-1 m
 □ Hg=Ht-1.8 m

14	BCF052	2/4 M45
13	BAF052	2/4 M42
12	BPF117	4/4 M45-45
11	BNF117	4/4 M45-42
10	BOF117	4/4
9	BOF039	4/4
8	BO039	2/2
7	STR039	2/2
6	SBR117	4/2
5	SBR039	4/2
4	SB117	4/2
3	SB039	4/2
2	ST117	2/2
1	ST039	2/2

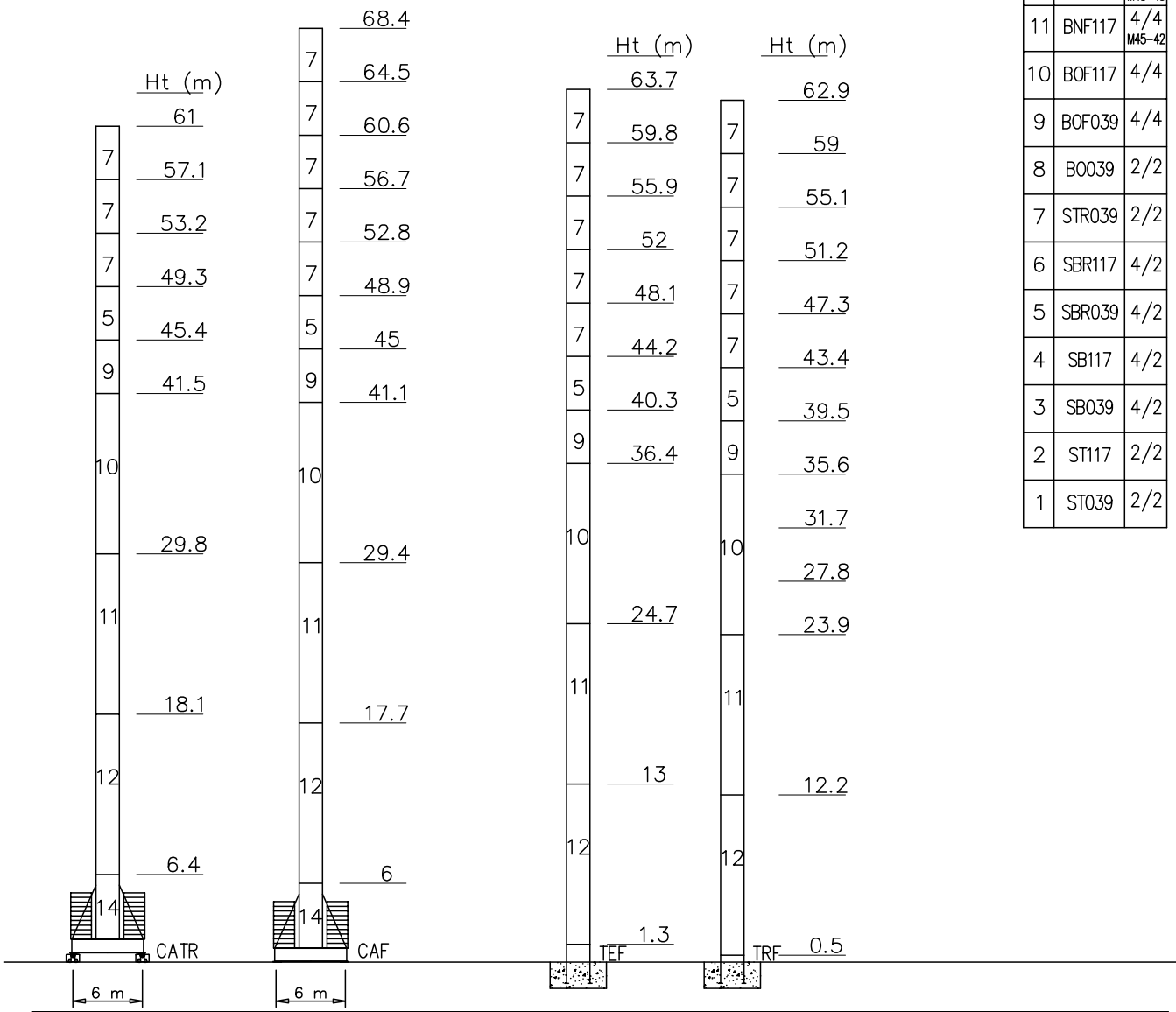

Peso zavorra – Ballast weight – Poids du lest – Ballastgewicht – Peso de lastre

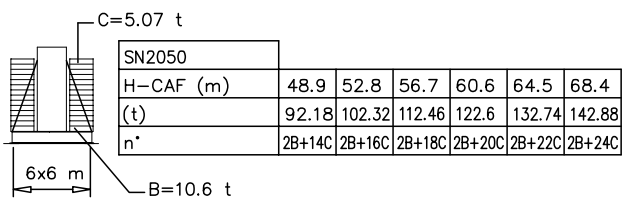
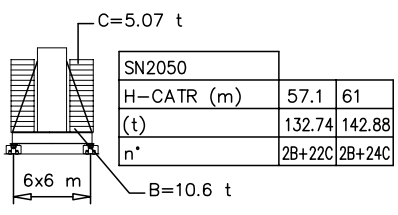

Torre/Reazioni – Masts/Reactions – Mat/Réactions – Maste/Eckdrücke – Mástil/Reacciones – Tramo/Reacções

SN2050 EN14439-D25

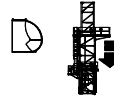
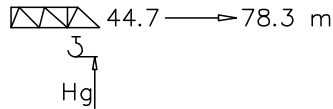

- Hg=Ht-1 m
- Hg=Ht-1.8 m

14	BCF052	2/4 M45
13	BAF052	2/4 M42
12	BPF117	4/4 M45-45
11	BNF117	4/4 M45-42
10	BOF117	4/4
9	BOF039	4/4
8	BO039	2/2
7	STR039	2/2
6	SBR117	4/2
5	SBR039	4/2
4	SB117	4/2
3	SB039	4/2
2	ST117	2/2
1	ST039	2/2

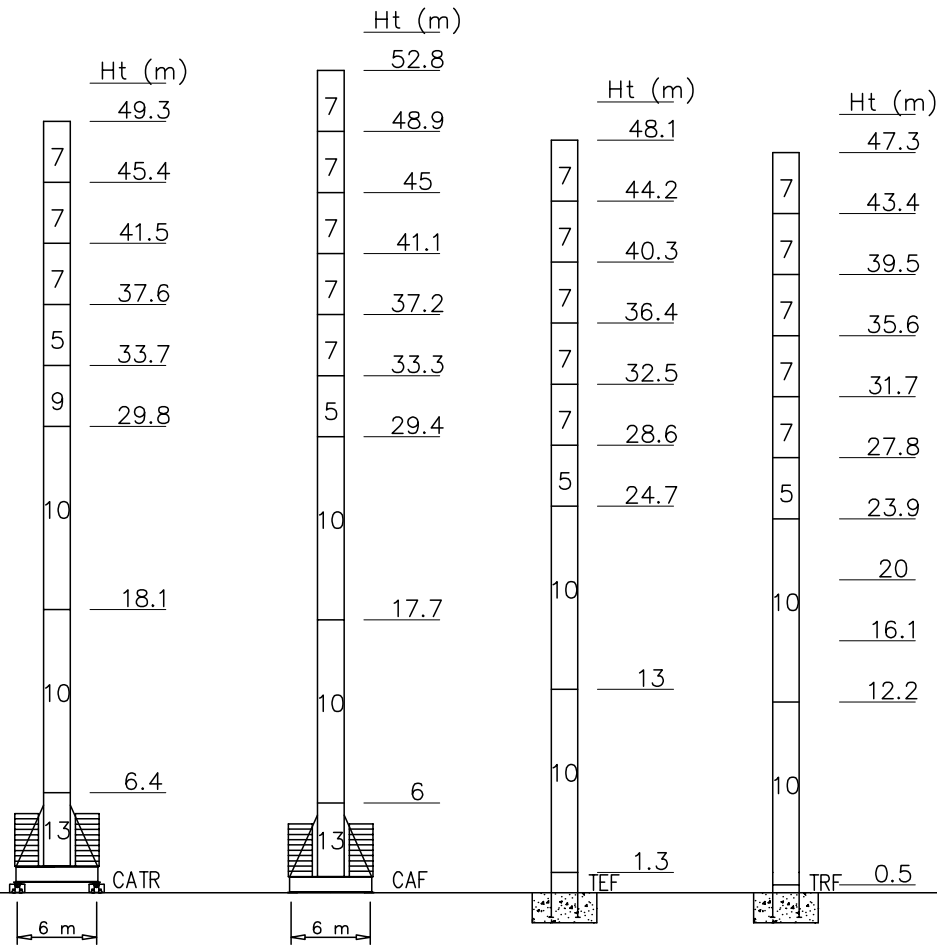

Peso zavorra – Ballast weight – Poids du lest – Ballastgewicht – Peso de lastre

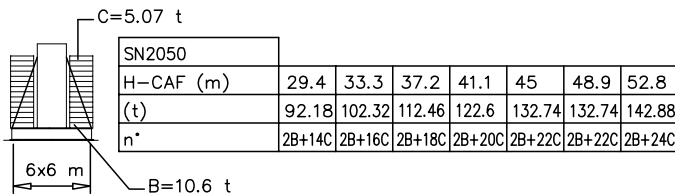
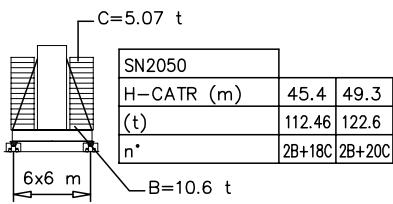

Torre/Reazioni – Masts/Reactions – Mat/Réactions – Maste/Eckdrücke – Mástil/Reacciones – Tramo/Reacções

SN2050 EN14439-D25

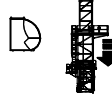
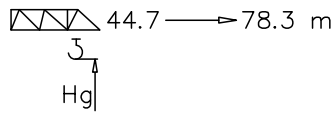

- Hg=Ht-1 m
- Hg=Ht-1.8 m



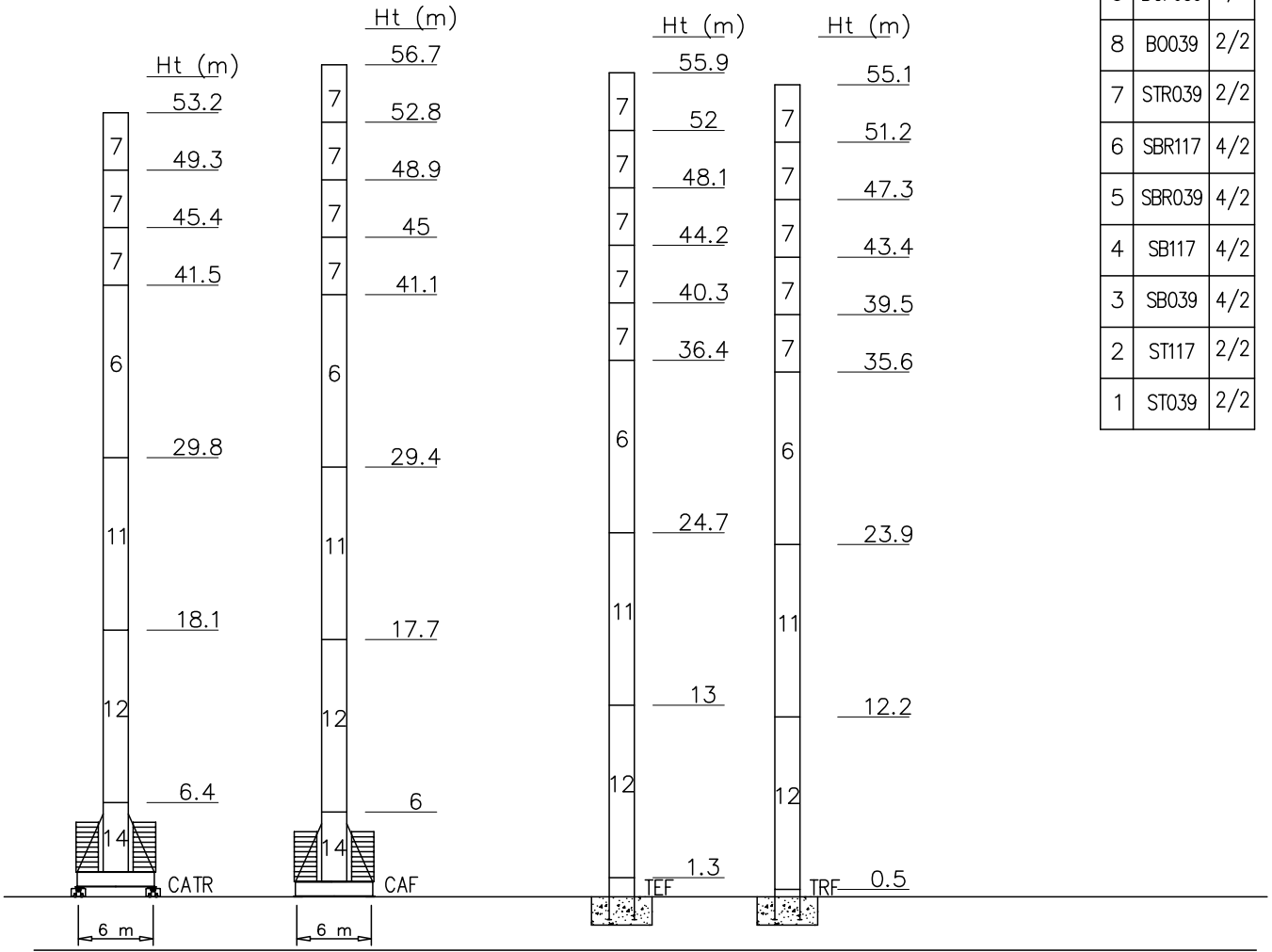

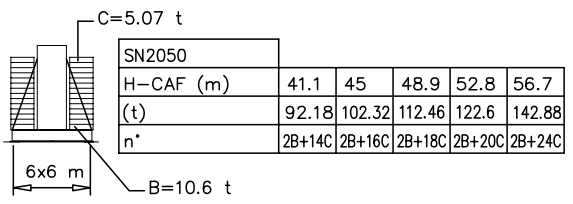
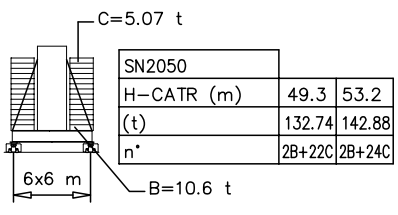

14	BCF052	2/4 M45
13	BAF052	2/4 M42
12	BPF117	4/4 M45-45
11	BNF117	4/4 M45-42
10	BOF117	4/4
9	BOF039	4/4
8	BO039	2/2
7	STR039	2/2
6	SBR117	4/2
5	SBR039	4/2
4	SB117	4/2
3	SB039	4/2
2	ST117	2/2
1	ST039	2/2



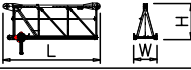
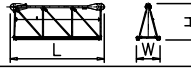

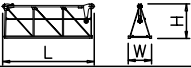
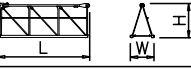
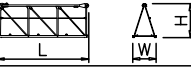
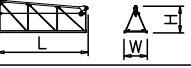
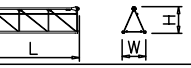
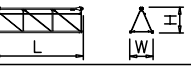
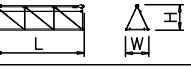
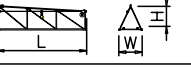
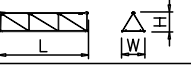
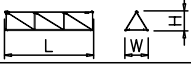
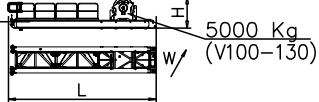
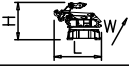

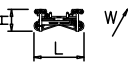
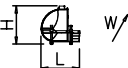





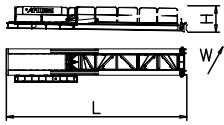

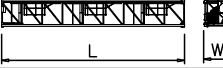

Peso zavorra – Ballast weight – Poids du lest – Ballastgewicht – Peso de lastre

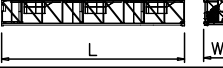

PESI E INGOMBRI – PACKING LIST – LISTE DE COLISAGE – GEWICHT UND ABMESSUNGEN

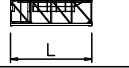
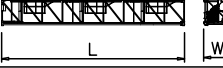
Denominazione Description	Disegno Draw	Pezzi Pieces	Dimensioni-Dimensions (mm)			Peso-Weight (kg)		
			L	W	H	Unit	Total	
Elemento di braccio Jib element Elément de èche Elemento de flecha (78 m. jib version)	n°14 	1	6230	1540	2320	3737	–	
	n°13 	1	6000	1500	2320	2439	–	
	n°12 	1	5960	1500	2250	2408	–	
	n°11 	1	5960	1500	2230	1894	–	
	n°10 	1	5860	1500	2216	1633	–	
	n°9 	1	5875	1500	2196	1392	–	
	n°8 	1	5840	1500	2176	1229	–	
	n°7 	1	5830	1500	1730	1025	–	
	n°6 	1	5820	1500	1700	913	–	
	n°5 	1	5800	1500	1670	766	–	
	n°4 	1	5775	1500	1600	610	–	
	n°3 	1	5740	1500	1600	475	–	
	n°2 	1	5736	1500	1280	377	–	
	n°1 con punta braccio 	1	6000	1500	1280	330	–	
Contorbraccio completo Complete counterjib Contreflèche complète Contraflecha completa	5000 Kg  5000 Kg (V100-130)	1	9500	2400	2010	10000	–	
Gruppo girevole Slewing group Table tournante Grupo giratorio	SN2050 	1	3035	2230	2370	9000	–	
	SP2300 	1	3035	2230	2370	9500	–	
Carrello Trolley Chariot Carretilla	P16 	1	1970	1910	815	600	–	
Ballatoio con cabina Access balcony with cabin Porte cabine Balcòn corrido con cabina		1	2500	2150	2450	1000	–	
Blocchi contrappeso Counterweight block Contre-poids Bloques de contrapeso	VX32 	VS15	2	1000	200	3550	1560	3120
	VS15 		6	1000	400	3550	3120	18720

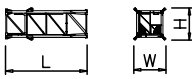
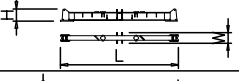
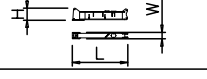
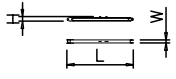
PESI E INGOMBRI – PACKING LIST – LISTE DE COLISAGE – GEWICHT UND ABMESSUNGEN

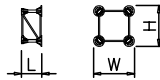
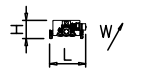
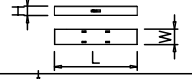
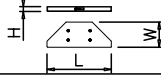
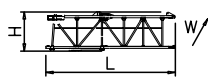
Denominazione Description	Disegno Draw	Pezzi Pieces	Dimensioni-Dimensions (mm)			Peso-Weight (kg)		
			L	W	H	Unit	Total	
Controbraccio counter jib Contrefleche Contraflecha			11500	2360	1600	8900		
Elemento di torre Mast element Elément de mature Elemento de torre	ST039 	SP2300	–	3900	2360	2360	2603	–
	STR039 	SN2050	–	3900	2110	2110	2320	–
	STD052 	SP2300	–	5200	2360	2360	3198	–
		SN2050	–	5200	2110	2110	2850	–
	ST117 	SP2300	–	11700	2360	2360	6475	–
		SN2050	–	11700	2110	2110	5790	–
	SB039 	SP2300	–	3900	2360	2360	3031	–
	SBR039 	SN2050	–	3900	2110	2110	2710	–
	SB052 	SP2300	–	5200	2360	2360	3470	–
	SBR052 	SN2050	–	5200	2110	2110	3350	–
		SB117 	SP2300	–	11700	2360	2360	7830
	SBR117 	SN2050	–	11700	2110	2110	7000	–
BOF039 	SP2300	–	3900	2360	2360	4210	–	
BOF052 	SN2050	–	3900	2110	2110	3770	–	
	SP2300	–	5200	2360	2360	4340	–	
BOF117 	SN2050	–	5200	2110	2110	3880	–	
	BNF117 	SP2300	–	11700	2360	2360	9150	–
BPF117 	SN2050	–	11700	2110	2110	8180	–	
	Elemento di base Base element Mat de base Elemento de base		SP2300	1	6500	2360	2360	4550
		SN2050	1	5200	2260	2260	4040	–
Carro di base Base carriage Chassis de base Cruceta de base		8x8	1	11830	670	780	3340	3340
		6x6	1	8870	670	780	2500	2500
		8x8	2	5760	420	780	1600	3200
		6x6	2	4320	420	780	1200	2400
Puntoni di base Rafter Jambes de force Cabrios de base		8x8	4	6080	420	300	560	2240
		6x6	4	4560	420	300	420	1680
Elemento a perdere Disposable frame Chassis a perdre Bastidor desechable		SP2300	1	3000	2360	2360	2350	–
		SN2050	1	2600	2260	2260	2030	–
Elemento recuperabile Recoverable frame Chassis récupérable Bastidor recuperable		SP2300	1	1300	2900	2900	2100	–
		SN2050	1	1300	2620	2620	1860	–
Bogie di traslazione Driven bogie Boggie motorisèe Balancin de traslaciòn			4	1160	700	600	700	2800
Blocco zavorra di base Base ballast block Lest de base Blaque de lastre		8x8	2	8300	1200	600	11900	23800
		6x6	2	6400	1200	600	10600	21200
		8x8	–	6400	1600	300	5700	–
		6x6	–	4800	2000	300	5070	–
Corsoio di montaggio Climbing cage Cage de montage Jaula de montaje		SP2300	1	8300	3250	3000	7500	–
		SN2050	1	8300	2900	2700	6700	–

GRU IN CAVEDIO – TELESCOPAGE SUR DALLES – CLIMBING CRANE – KLETTERKRANE IM GEBAUDE

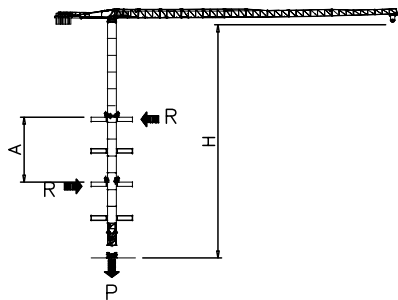

SN2050	H (m)	A (m)
	50.8	Min 9
Apertura passaggio gru Opening for crane passing 		Max 12

SOPRALZO IDRAULICO – TELESCOPABLE – EXTERNAL CLIMBING – KLETTERKRANE

FEM

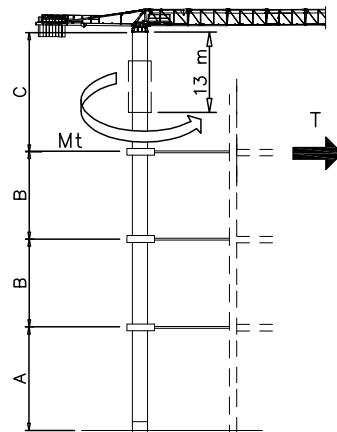

	<input checked="" type="checkbox"/>	SN2050-M42	SN2050-M45
MAX	C	32.5 m	32.5 m
	B	19.5 m	19.5 m
	A	39 m	50.7 m
		Hmax+11.7 m	

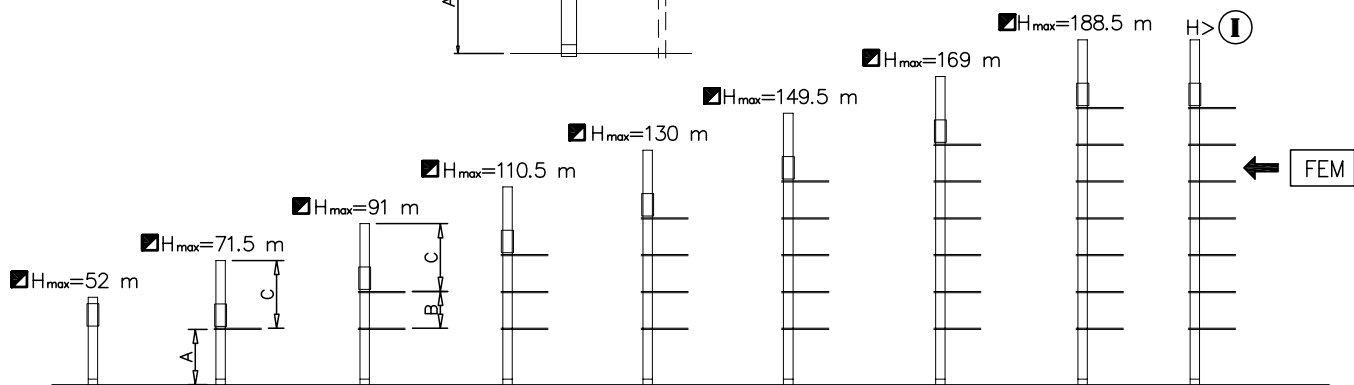



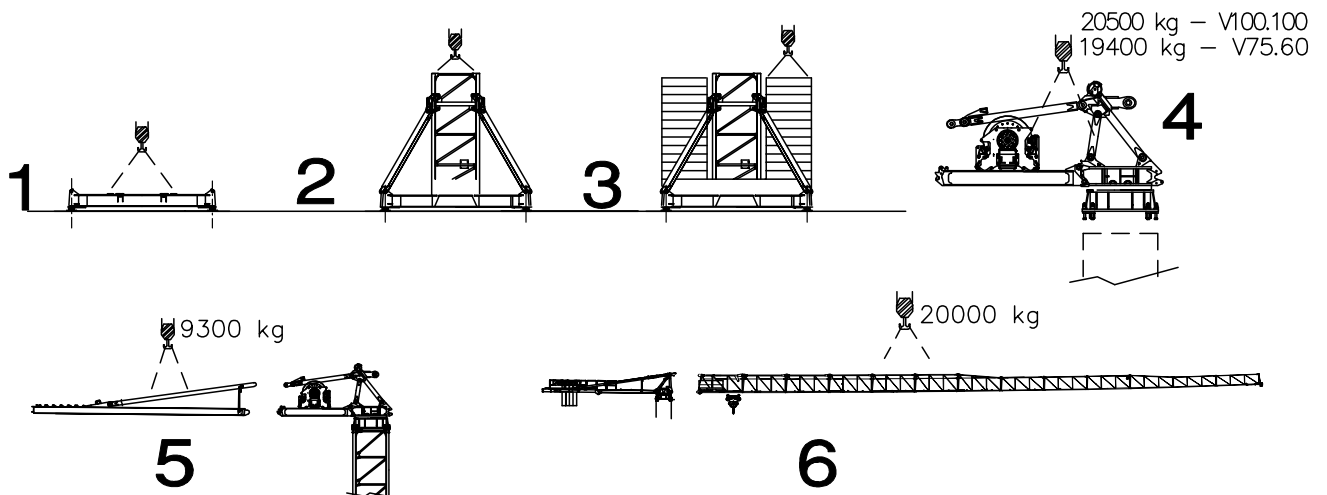

Montaggio – Montage – Erection – Montage – Montaje – Montagem



Meccanismi – Mechanisms – Mécanismes – Antriebe – Mecanismos

Sollevamento Hoisting Levage Heben Elevaciòn Elevaçao	V75.60													 V75.60 55 kW 85 kVA 240 m 480 m (L)
		m/min	2	20	31	46	60	72	1	10	15	23	30	
	t	8	8	7	4.5	3	1.4	16	16	14	9	6	2.8	
Sollevamento Hoisting Levage Heben Elevaciòn Elevaçao	V100.100													 V100.100 75 kW 110 kVA 352 m 704 m (L)
		m/min	4	21	40	64	86	100	2	10	20	32	43	
	t	8	8	8	5.5	3.8	2	16	16	16	11	7.6	4	
Sollevamento Hoisting Levage Heben Elevaciòn Elevaçao	V100.130													 V100.130 75 kW 110 kVA 360 m 750 m (L)
		m/min	6	28	54	86	115	130	3	14	27	43	57	
	t	6	6	6	4	2.8	1.4	12	12	12	8	5.6	2.8	
Sollevamento Hoisting Levage Heben Elevaciòn Elevaçao	V170.170													 V170.170 125 kW 150 kVA 388 776 m (L)
		m/min	7	36	73	118	148	177	3.5	18	36.5	59	74	
	t	8	8	8	4.1	3.1	1.3	16	16	16	8.2	6.2	2.6	

Meccanismi – Mechanisms – Mécanismes – Antriebe – Mecanismos

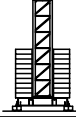
Carrello Trolleying Distribution Katzfahren Distribucióh Distribuiçao			0 → 80 0 → 120 OP	m/min	7.5 kW	Potenza elettrica necessaria Puissance électrique nécessaire Necessary electric power Anschlusswert – Potencia
Rotazione Slewing Orientation Schwenken Orientaciòh Rotaçao			0 → 0,9	giri/min tr/min rp/min	16 kW @ 1200rpm n° 4 x 4 kW	
Traslazione Travelling Translation Kranfahren Traslaciòh Translaçao			0 → 20	m/min	9 kW	

Rete elettrica – Réseau – Mains supply – Netzstrom – Red – Rede electrica 400V – 50 Hz

FEM 1.001 – A4
 EN 14439 – C25 – D25