

WORKING DIMENSIONS

Length:	11.2 m (36 ft. 9 in.)
Width:	6.6 m (21 ft. 8 in.)
Height:	6.7 m (21 ft. 12 in.)
Weight:	55 tons

INTERNATIONAL SHIPPING DIMENSIONS

Shipping Method:	Five (5) containers 40'
------------------	-------------------------

FLOTATION

Dimensions:	Two pontoons 11.5 m x 2 m x 2 m with Central Floater
Draft:	80 – 90 cm

WORKING CAPACITY

Capacity:	200 m ³ /h – 800 m ³ /h (880 gpm – 3522 gpm)
Head:	58 m – 25 m (190 ft. – 82 ft.)
Working Depth:	Up to 7 m (23 ft.)

ENGINE

Type:	CAT or IVECO Diesel engine (260kW/348HP) (Other brands on demand)
Fuel Capacity:	1.000 liters
Fuel Consumption:	250 gr/kW/h

SUBMERSIBLE DREDGE PUMP

Type:	HY85/160A/B/HC
Discharge Diameter:	200 mm – 250 mm (8in. – 10 in.)
Impeller Diameter:	440 mm (1 ft. 5 in.) / 3 blades, closed
Max. Solid Handling:	60 mm (2.36 in.) / 90 mm (3.54 in.)
Speed:	980 r.p.m. / 1450 r.p.m (variable)
Oil requirements:	240 l/min @ 300 bar
Power:	120 kW (165HP)

EXCAVATORS

Diameter:	700 mm (2 ft. 3 in.)
Replaceable Teeth:	Regular, sharp or wide head teeth
Drive:	Radial piston hydraulic motor
Power:	9 kW (11 HP)
Oil requirements:	22 l/min - 29 l/min - 36 l/min @ 300 bar
Weight:	500 kg each
Speed:	30 r.p.m – 40 r.p.m – 50 r.p.m
Torque:	311 kgm – 313 kgm – 314 kgm
Rotation:	Both directions

OPTIONAL - JET RING SYSTEM

Water capacity	20 m ³ /h – 200 m ³ /h
Pressure:	6 bar – 7 bar
Drive:	On-barge horizontal hydraulic pump

PROPULSION

On land	Lateral tracked hulls
On water	– Four (4) 50 m steel Winches (available up to 200 m) – Helix Propeller (OPTIONAL)

ELECTRICAL SYSTEM

Voltage:	On request
Alternator Output:	24 V

SAFETY FEATURES

Includes:	2 fire extinguishers, hand rail, folding cabin door, warning horn, life rings, life jackets, locking power unit.
-----------	--

ANTI-CORROSION FEATURES

Includes:	Hull below deck painted with marine-grade epoxy. Hull above deck painted with polyurethane epoxy and remaining components coated with heavy-duty powder coating all suitable for salt-water service.
-----------	--

EQUIPMENT	BASIC	STANDARD	FULL OPTIONAL
Winches for moving	X	X	X
Night time operating lights	X	X	X
Operator Cabin	X	X	X
Control Panel	X	X	X
Sound Proof Canopy		X	X
A/C and Heating		X	X
Polymer tracks		X	X
Dredge GPS System			X
Helix Propeller			X
Stabilizer Spuds			X
TIER3 B (OPTIONAL)			
TIER4 FINAL (OPTIONAL)			
R.I.N.A. Certification (OPTIONAL)			



THE DREDGE

Hydraulic Power Pack

- Separate oil pumps for pump and excavators
- Sound Proof Canopy
- IVECO, VOLVO or CAT engine
- Closed hydraulic circuit
- Completely customizable hydraulic circuit

Operator Cabin

- Complete Control panel
- Equipped with heating and air conditioning
- Operator chair
- Safety equipment
- Equipment status
- Emergency Stop controls



Hydraulic Arm

- Carefully move pump around
- Depth measuring gauge
- Possibility to install other hydraulic tools



Winches (x4)

- Used for moving and fixing the dredge
- Steel cables
- Optional propeller
- Stabilizer Spuds (x4)

Floaters

- Two (2) pontoons 11.2 m x 2 m x 2 m with central floater
- Small draft

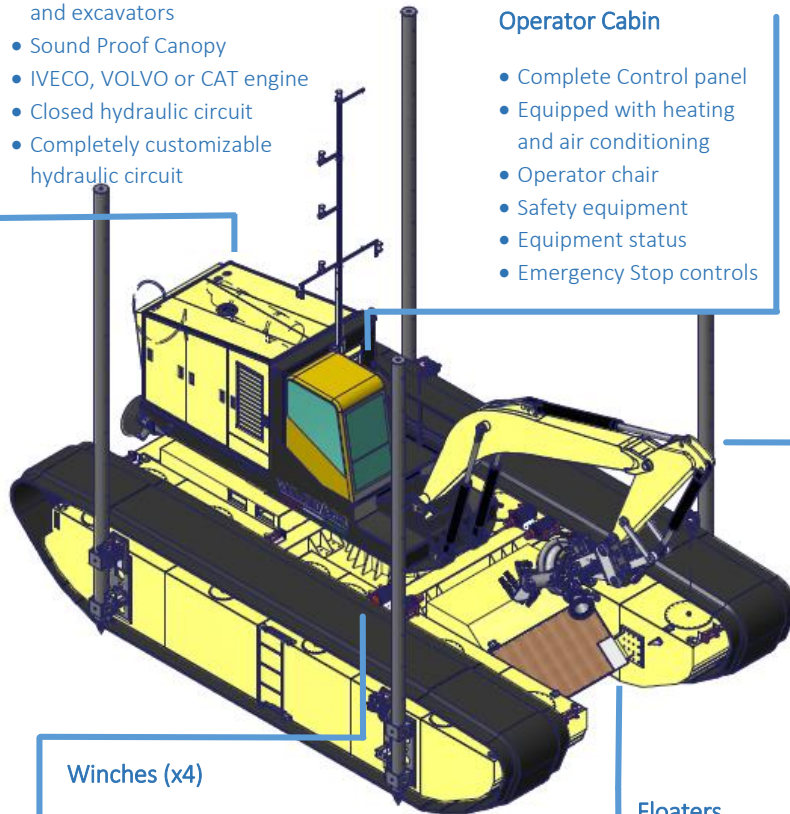

THE PUMP

Excavators

- Diameter: 700mm
- Replaceable teeth
- Radial piston hydraulic motor
- Oil requirement: 35 l/min each
- Weight: 500kg
- Speed: 30 r.p.m. – 50 r.p.m.
- Torque: 314 kgm
- Rotates in both directions

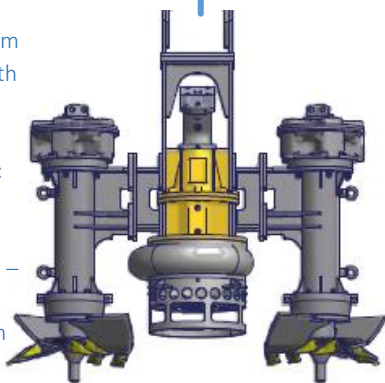

Pump

- Capacity: 200 m³/h – 800 m³/h
- Head: 58 m – 25 m
- Discharge diameter: 200mm – 250mm
- Suction diameter: 548mm
- Impeller diameter: 440mm
- Max. solid handling: 60mm – 90 mm
- Speed: 1450 r.p.m.
- Oil requirement: 240 l/min

Jet-Ring System

- Water Capacity: 20 m³/h – 200 m³/h
- Pressure: 6 bar – 7 bar
- Drive: Horizontal high pressure pump

