

ILF KOMMUNAL

LA MACCHINA INDISPENSABILE
THE INDISPENSABLE MACHINE



MANUTENZIONE DEL VERDE
VEGETATION MAINTENANCE



FORESTALE
FORESTRY



VIABILITÀ INVERNALE
WINTER ROAD SERVICE



MOVIMENTAZIONE
HANDLING



ILF SEMOVENTI
SELF-PROPELLED



ENERGREEN®
Professional Machines

INDICE / INDEX

- 4 ▶ **PUNTI DI FORZA**
STRENGTHS
- 6 ▶ **1000 APPLICAZIONI**
1000 APPLICATIONS
- 8 ▶ **VISIBILITÀ ESTREMA**
EXTREME VISIBILITY
- 10-11 ▶ **COMFORT ASSOLUTO**
ABSOLUTE COMFORT
- 12-13 ▶ **CABINA**
CABIN
- 14-15 ▶ **MULTIFUNZIONALE**
MULTIFUNCTIONAL
- 16-17 ▶ **ATTACCO RAPIDO**
QUICK ATTACHMENT
- 18-19 ▶ **MANUTENZIONE DEL VERDE**
VEGETATION MAINTENANCE
- 20-21 ▶ **BRACCI TELESCOPICI**
TELESCOPIC ARMS
- 22-23 ▶ **LAVORI DA CANTIERE**
CONSTRUCTION WORKS
- 24 ▶ **CARICATORE FRONTALE**
FRONT LOADER
- 25 ▶ **SOLLEVATORE "HERCULES"**
LINKAGE "HERCULES"
- 26-27 ▶ **VIABILITÀ INVERNALE**
WINTER ROAD SERVICE
- 28 ▶ **MANOVRABILITÀ**
MANEUVERABILITY
- 29 ▶ **QUALITÀ DEI COMPONENTI**
QUALITY COMPONENT
- 30 ▶ **AUTO LUBE - INGRASSAGGIO AUT. BRACCIO**
AUTOMATIC GREASING SYSTEM OF THE ARM
- 31 ▶ **CONNECT - ATTACCO RAPIDO ATTREZZATURE**
CONNECT - QUICK ATTACHMENT SYSTEM
- 32-33 ▶ **DATI TECNICI & DIMENSIONI**
TECHNICAL DATA & DIMENSIONS



ILF KOMMUNAL



ILF KOMMUNAL

ILF KOMMUNAL è una macchina multifunzionale estremamente versatile. Polivalenza e multifunzionalità all'ennesima potenza. Macchina ideale per operare tutto l'anno con diverse attrezzature, la stessa dispone di un particolare sistema di scarramento anteriore che consente la intercambiabilità degli attrezzi in pochi minuti, impegnando un solo operatore senza l'ausilio di mezzi di sollevamento, il tutto in assoluta sicurezza. ILF KOMMUNAL è una macchina estremamente affidabile e sicura in ogni contesto operativo, grazie alla vasta gamma di attrezzature, risulta essere a tutti gli effetti la migliore soluzione per comuni, amministrazioni ed enti pubblici.

ILF KOMMUNAL is an extremely versatile and multifunctional machine. Versatility and multi-functionality at full power. This machine is appropriate to work all year with different equipment; it is equipped with a particular special moving front system that allows to interchange all tools in few minutes, with the help of only one operator, without the employment of particular lifting means, all in complete safety. ILF KOMMUNAL is an extremely safe and reliable machine, in every work environment, thanks to the wide range of tools; indeed, it appears to be the best solution for councils, public entities bodies and administrations.



MULTIFUNZIONALE MULTIFUNCTIONAL

ILF KOMMUNAL può montare anteriormente e posteriormente numerose attrezzature per la cura del verde stradale o forestale, la viabilità invernale, il movimento terra o lavori da cantiere. Anteriormente può dotarsi di robusti bracci telescopici fino a 7,2 metri, con l'applicazione terminale di varie attrezzature. Inoltre lateralmente può montare un utilissimo disco falciante per guardrail.

ILF KOMMUNAL can be fitted front and rear attachments for the maintenance of vegetation both in roads and in forests. There are attachments available for winter maintenance, earthmoving or construction works. Robust telescopic arms up to 7.2 meters, they can be fitted with various attachments. In addition, a useful mowing disk can be mounted on the right side of the machine.



MANOVRABILITÀ MANEUVERABILITY

- Trazione integrale: 2 ruote sterzanti, 4 ruote sterzanti e a granchio.
- Lavoro bi-direzionale.
- Four wheel drive, four steering wheels with three types of steering: 2 steering wheels, 4 steering wheels and crab steering.
- Bidirectional work.

SICUREZZA E COMFORT SAFETY AND COMFORT

- Cabina omologata FOPS-ROPS.
- Vetro panoramico ad alta visibilità.
- Ottima ergonomia di lavoro.
- Controllo della stabilità.
- FOPS-ROPS Homologated cabin.
- High visibility panoramic windscreen.
- Excellent ergonomics.
- Stability Control.

MAGGIORE PRODUTTIVITÀ GREATER PRODUCTIVITY

- Aggancio rapido idraulico delle attrezzature.
- Più attrezzature applicabili contemporaneamente.
- Massima manovrabilità su tutti i terreni.
- Potenza idraulica e tecnologia operativa.
- Quick Connection System for the equipment.
- More tools applicable at the same time.
- Maximum maneuverability on all fields.
- Hydraulic power and operational technology.

ESTREMA VISIBILITÀ EXTREME VISIBILITY

Massima visibilità a 360° con ampia vetratura per il pieno controllo dell'ambiente di lavoro.
Maximum 360° visibility with large windows for the full monitoring of the working environment.

QUALITÀ QUALITY

- Telaio rinforzato in acciaio speciale STRENX®.
- Componenti certificati.
- Motori Tier 4F potenti e collaudati.
- Trasmissioni idrostatiche HEAVY DUTY.
- Reinforced frame made of special steel STRENX®.
- Certified components.
- Powerful and tested engines Tier 4F.
- HEAVY DUTY hydrostatic transmissions.



PUNTI DI FORZA STRENGTHS



MACCHINA POLIVALENTE PER 1000 APPLICAZIONI

ILF KOMMUNAL è una macchina polivalente, impareggiabile per chi utilizza continuamente o saltuariamente attrezzature particolari come bracci con benne da scavo, pale per movimento terra, lame da neve o spazzaneve, forche idrauliche di sollevamento, attrezzature frontali per sfalcio erba oppure su braccio idraulico, taglia siepi, attrezzature agricole con attacchi standard a 3 punti con sollevatore idraulico e cardano, spazzole, attrezzature speciali a disegno.

POLYVALENT MACHINE FOR 1000 APPLICATIONS

ILF KOMMUNAL is a polyvalent machine, which is incomparable for operators who use continuously or occasionally booms equipped with excavator buckets, loader shovels, snow blades or snow blowers, hydraulic lift forks, front equipment for grass mowing or placed on an hydraulic boom, hedge trimmers, agricultural accessories with standard three-points connection with hydraulic lifter and universal joint, rotary brushes, special accessories on demand.



1000 APPLICAZIONI 1000 APPLICATIONS

VISIBILITÀ ESTREMA

AMPIA
VETRATURA
PER IL PIENO
CONTROLLO
DELL'AMBIENTE
DI LAVORO

EXTREME VISIBILITY

LARGE
WINDOWS
FOR THE FULL
MONITORING
THE WORKING
ENVIRONMENT

MASSIMA VISIBILITÀ A TUTTO CAMPO

La prima caratteristica che colpisce appena si sale a bordo è l'ampia vetratura, che offre massima visibilità sui 360 gradi, per il pieno controllo dell'ambiente di lavoro. Il volante regolabile, come il confortevole sedile ed il sistema di comandi ergonomici ed intuitivi, creano subito un forte feeling tra l'operatore e la macchina, subito pronta a rispondere con fluidità ai comandi, per rendere leggera qualsiasi giornata di intenso lavoro.

EXTREME ALL-ROUND VISIBILITY

The first surprising feature inside the cabin are the wide glasses, that guaranties maximum visibility at 360 degrees for a full control on the working area. The adjustable steering wheel, the comfortable seat and the ergonomic and intuitive devices system establish a strong feeling between the operator and the machine with its fluidity in all drives in order to make easier every day of hard work.



COMFORT ASSOLUTO ABSOLUTE COMFORT



3 STILI IN CABINA 3 STYLES IN THE CABIN

La spaziosa cabina omologata FOPS-ROPS è disponibile in tre diversi allestimenti, per rendere il tuo lavoro sempre più facile e comodo.

The spacious cabin certified FOPS-ROPS is available in three versions, to make your work easier and more comfortable.



**CABINA/CABIN
STANDARD**



**CABINA/CABIN
COMFORT**



**CABINA/CABIN
PRESTIGE**

MASSIMA SICUREZZA E PROTEZIONE

La cabina è omologata FOPS-ROPS garantendo la protezione contro ribaltamenti e cadute di oggetti. Essa è dotata di sistema di sigillatura attraverso morbide guarnizioni sulle vetrate fissate e mobili, montata su supporti elastici nei punti di appoggio, risulta completamente isolata ed efficientemente climatizzata rendendo la macchina adatta a lavori in ambienti polverosi e rumorosi per molte ore al giorno in completo comfort, come è nella filosofia Energreen.

MAXIMUM SAFETY AND PROTECTION

The cabin is certified according to FOPS-ROPS regulations, which guarantees the protection against overturning and objects fall. The cabin is completely sealed through flexible gaskets fitted on all fixed and moving glasses and installed on elastic brackets on support points, is completely isolated and efficiently air conditioned. It makes the machine suitable for working in dusty and noisy situations for many hours per day giving to the operator complete comfort, which is at the base of the Energreen philosophy.



**CABINA/CABIN
STANDARD**

- Volante inclinabile e regolabile.
- Computer di bordo.
- Colonna sterzo inclinabile.
- Sedile pneumatico regolabile.
- Inversore elettrico della direzione.
- Aria condizionata.
- Filtro aria condizionata anti-polline.
- Bracciolo regolabile con Joystick.
- Vetri posteriori oscurati anti u.v.
- Tergi lava-cristallo anteriore.
- Lampada rotante LED
- Porta cabina divisibile 60/40.
- Porta oggetti posteriore.
- Luce di cortesia interna.
- Martelletto di emergenza.
- Predisposizione alloggio estintore.
- Stacca batterie automatico.
- Presa elettrica esterna 12 volt.
- Svuota tasche laterale.
- Porta documenti.
- Accendisigari 12 volt.
- Abilitazione funzioni invernale.

- Tilting and adjustable steering wheel.
- On-board computer.
- Tilting and height-adjustable steering column.
- Adjustable air suspension seat.
- Electric reverser of the direction.
- Air conditioning system.
- Anti-pollen air conditioning filter.
- Adjustable armrest with joystick.
- Rear windows darked anti u.v.
- Front windscreen wiper.
- Rotating LED lamp.
- Divisible cabin door 60/40.
- Rear glove box.
- Internal courtesy light.
- Emergency glass breaking hammer.
- Provision for fire extinguisher.
- Automatic switch cut-off of the battery.
- External electrical socket 12 volt.
- Side pocket.
- Document holder.
- Cigarette lighter.
- Foldable ladder step.



**CABINA/CABIN
COMFORT**

In aggiunta all'allestimento "CABINA STANDARD"

- Cruise Control.
- Pedale inversione istantanea.
- Autoradio Bluetooth/DAB.
- Sedile con ammortizzatore lombare.
- Potenzimetro elettronico per cilindrata pompa fresa.
- Tendina parasole auto-avvolgente su parabrezza.
- Fari di lavoro a LED.
- Appendi abiti.
- Specchio destro retrovisore.

In addition to the installation of the "STANDARD CABINE"

- Cruise Control.
- Pedal for instantaneous inversion.
- Radio with Bluetooth/DAB.
- Seat with shock absorber for the lumbar side.
- Potentiometer for changement the displacement of the implement.
- Windscreen curtain with self-wrapping.
- LED working lights.
- Coat hanger.
- Right rear-view mirror.



**CABINA/CABIN
PRESTIGE**

In aggiunta all'allestimento "CABINA COMFORT"

- Monitor con 1 telecamera.
- 2° lampeggiante.
- Kit oblò con grata, tendina e tergicristallo.
- Tendina laterale.
- Tergicristallo laterale destro.
- Estintore.

In addition to the installation of the "COMFORT CABINE"

- Monitor screen with 1 camera.
- Second flashing lights.
- Porthole with grille, curtain and windscreen wiper.
- Lateral curtain.
- Windshield wiper on the right side.
- Fire extinguisher.



**MONITOR CON
TELECAMERA
MONITOR SCREEN
WITH CAMERA**

ALLESTIMENTO / EQUIPMENT LINE PRESTIGE



A MISURA DEL TUO LAVORO

L'idea alla base del progetto **ILF KOMMUNAL** è l'estrema configurabilità della macchina. Il sistema di sgancio ed aggancio rapido delle attrezzature consente inoltre una rapida riconfigurazione del mezzo, per poter passare da una tipologia di lavoro ad un'altra completamente diversa, utilizzando lo stesso mezzo, con una notevole economia di costi di gestione e ampia scelta di attrezzature disponibili, oppure adattabili su richiesta e progettazione specifica in base alle necessità del Cliente.

CUSTOM-MADE FOR YOUR WORK

At the base of the project of **ILF KOMMUNAL** there's the idea of the extreme customization of the machine. Moreover, the rapid coupling and uncoupling of the accessories allow a quick and new configuration of the ILF 1000 Kommunal. In order to move from a type of work to a completely different one, by using the same machine, with the advantages of remarkable costs reduction and wide choice of available accessories, adaptable equipment on demand or specifically designed to satisfy the Customer requests.

APPLICAZIONI FRONTALI

- A1** • Braccio telescopico FAST 7 / 6
- Braccio telescopico COMPACT 6.5 / 7.2
- Caricatore frontale
- Benna multiuso
- Benna miscelatrice
- Forche pallet

- A2** • Lame sgombraneve
- Vomere sgombraneve
- Turbofresa
- Falciatrice per guardrail

- A3** • Trinciatrice
- Spazzatrice
- Lavagemme e barriere stradali
- Zavorra per traino

APPLICAZIONE LATERALE

- B** • Disco falciante mod. Shrek

APPLICAZIONI POSTERIORI

- C** • Soffiatore
- Spargisale
- Gancio traino

FRONT APPLICATIONS

- A1** • Telescopic arm FAST 7 / 6
- Telescopic arm COMPACT 6,5 / 7.2
- Front loader
- Multipurpose bucket
- Concret mixer bucket
- Pallet forks

- A2** • Snow blade
- Snow ploughshare
- Snow blower
- Guardrail mower

- A3** • Mower
- Sweeper
- Traffic signals and road barrier cleaner
- Towing ballast

LATERAL APPLICATION

- B** • Lateral mowing disc mod. Shrek

REAR APPLICATIONS

- C** • Blower
- Salt spreader
- Tow hook

MULTIFUNZIONALE MULTIFUNCTIONAL

ATTACCO POSTERIORE A 3 PUNTI FISSO

FIXED REAR 3 POINTS-CONNECTION



ATTACCO LATERALE CON DISCO FALCIANTE "SHREK"

LATERAL MOWING DISC MOD. SHREK



ATTACCO A 3 PUNTI "HERCULES"

FIXED REAR 3 POINTS PTO



ATTACCO FRONTALE CON INNESTO RAPIDO

FRONT ATTACHMENT WITH QUICK CONNECTION
Pagina/page 16-17

ESTREMA CONFIGURABILITÀ EXTREME CUSTOMIZATION

ATTACCO UNIVERSALE CON PIASTRA DIN

UNIVERSAL FRONT ATTACHMENT
CONNECTION WITH PLATE DIN



ATTACCO RAPIDO QUICK ATTACHMENT

A1

A1



CIRCUITI IDRAULICI DI COLLEGAMENTO
HYDRAULIC CONNECTION CIRCUITS



1 **MACCHINA SENZA ALLESTIMENTO**
MACHINE WITHOUT EQUIPMENT

2 **ALLINEARE LA MACCHINA ALL'ATTREZZATURA**
ALIGN THE MACHINE TO THE EQUIPMENT

3 **INFILARE LE GUIDE E AGGANCIARE L'ATTREZZO**
INSERT THE GUIDES AND ATTACH THE EQUIPMENT

4 **COLLEGARE TUTTI I CIRCUITI IDRAULICI TRAMITE UN'UNICA PIASTRA**
CONNECT ALL HYDRAULIC CIRCUITS BY USING ONE SINGLE PLATE

SEMPLICE E VELOCE ATTACCO FRONTALE

La necessità di poter agganciare le attrezzature con un solo operatore, senza la necessità di chiedere aiuto fisico ad altre persone, ha ispirato la progettazione del sistema di aggancio Energreen esclusivo della **ILF KOMMUNAL**. Il sistema è semplice: allineare la macchina all'attrezzatura da utilizzare, infilare le guide, bloccare il tutto con il dispositivo di aggancio idraulico, collegare tutti i circuiti idraulici con un'unica piastra, ... e pronti per la massima operatività! Nuova anche l'interfaccia di innesto degli allacciamenti idraulici, che essendo un'unica piastra di collegamento permette di non invertire accidentalmente i circuiti idraulici, e dotata di sistema di scarico delle pressioni residue per rendere agevole il blocco/sblocco del sistema.

EASY AND FAST FRONT ATTACHMENT

*The need to engage accessories, that can be made by only one operator in distant areas without the physical help of other people, has inspired the design of the exclusive coupling system Energreen **ILF KOMMUNAL**. The procedure is very easy: align the machine with the accessory that must be installed, connect the equipment to the machine chassis, block the unit through the hydraulic hook device, link all the hydraulic circuits with only a plate ... and now you're ready for the maximum practicality! The interface of the hydraulic pipes coupling is also new: an only connection plate permits to avoid to invert accidentally any hydraulic circuit thanks to the system of residual pressure drain in order to make lighter the block/unblock.*



MANUTENZIONE DEL VERDE



VEGETATION MAINTENANCE



**DISCO FALCIANTE MOD. SHREK
SIDE MOWING DISC MOD. SHREK**

NATURALMENTE GREEN

Energreen è specialista nelle macchine ed attrezzature per lo sfalcio dell'erba, naturalmente ha riversato la sua notevole esperienza in questa macchina. **ILF KOMMUNAL** è insuperabile per i lavori di manutenzione del verde della sede stradale e di altre attività inerenti al verde pubblico, con attrezzature specifiche ed affidabilissime, è la soluzione ideale, economica e tempestiva di tutte le esigenze stradali.

NATURALLY GREEN

Energreen is a specialist in machinery and accessories for grass mowing. Its remarkable experience has been transferred to this machine. ILF KOMMUNAL is unbeatable for works in vegetation maintenance along roads and other activities related to the public vegetation, with specific and reliable accessories. ILF KOMMUNAL is the perfect solution, cheap and reliable for all road maintenance needs and requests.

BRACCI TELESCOPICI / TELESCOPIC ARM



BRACCIO/ARM MOD. FAST



BRACCIO/ARM MOD. COMPACT



**SOFFIATORE
BLOWER**

ATTREZZATURE TERMINALI PER BRACCIO / EQUIPMENT TO BE ATTACHED TO THE ARM



**TESTATA TRINCIANTE
FLAIL HEAD**

NEW SPEED



RALLA CON ROTAZIONE DI 180° / SLEWING BEARING 180° ROTATION



**BARRA FALCIANTE
MOWING BAR**

CUT BAR



TRONCARAMI

POWER SHEARS



BARRA A DISCHI

DISCS BAR



**TESTATA TRINCIANTE
CON NASTRO**

CONVEYOR HEAD



**TESTATA FORESTALE
A DENTI FISSI**

FORESTRY HEAD

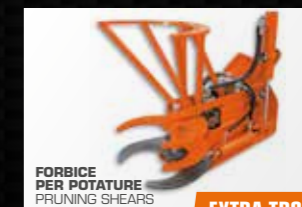

**FORBICE PER POTATURE
PRUNING SHEARS**

EXTRA TRONK



SPAZZOLA

IRON BRUSH



FRESA FOSSI

DITCH CLEANERS



BENNA PULIFOSSI

DITCH BUCKET

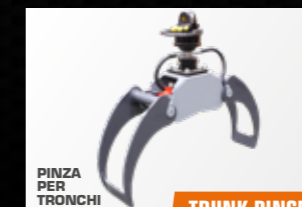

PINZA PER TRONCHI

TRUNK PINCERS

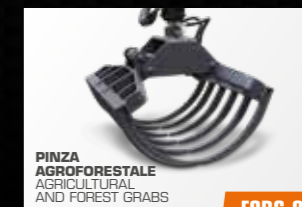

**PINZA AGROFORESTALE
AGRICULTURAL
AND FOREST GRABS**

FORC-ONE



FRESACEPPI

STUMP GRINDER

A1

BRACCIO COMPACT
COMPACT ARM



Il braccio **COMPACT** è stato progettato per lavorare in spazi ristretti. La sua geometria ne esalta le caratteristiche per lavori a filo ruota oppure per sfalcio di siepi o arbusti con testata in verticale fino ad una altezza di 9* metri circa. In particolare il braccio in queste configurazioni rimane sempre in sagoma permettendo di lavorare sempre all'interno di un ingombro veicolo di 2,2* metri.

The COMPACT arm has been designed to work in tight spaces. Its geometry enhances the characteristics of the machine. It allows to work side by side to the machine wheels, to mow hedges or bushes vertically up to a height of 9 meters. The arm in these configurations is always inside the machine profile, allowing to work always within a vehicle footprint of 2.2 meters*.*

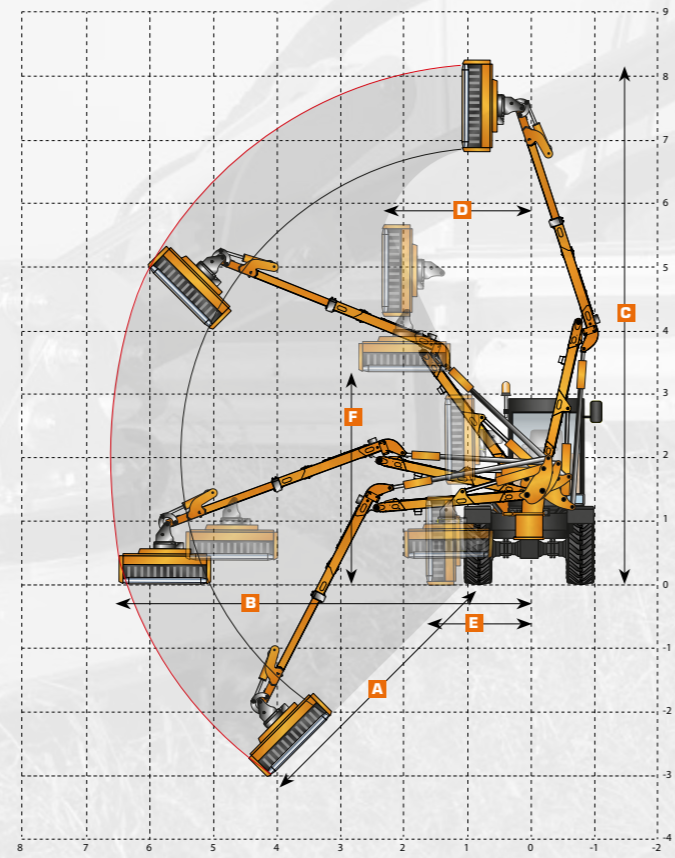

Mod.	A	B	C	D	E	F
6.5	4,5	6,5	8,4	2,4	1,2	3,4
7.2	5,1	7,2	9	2,4	1,2	3,4

* Misure variabili in base all'attrezzatura.
* Variable dimensions depending on the equipment.

Caratteristiche tecniche e costruttive soggette a modifica senza obbligo di notifica - Technical and construction specifications may be subject to change without prior notice



A1

BRACCIO FAST
ARM FAST

Il braccio telescopico **FAST** è stato progettato per lavorare con una estensione fino a 7* metri di profondità e di 8,4* m in altezza. La sua particolare geometria ne esalta le caratteristiche per lavori di manutenzione stradale ove si desidera un connubio tra sfalcio a bordo strada e lavori di rifinitura in profondità. Il robusto sfilo telescopico permette una maggiore agilità di lavoro e la massima performance anche in situazioni difficili.

The FAST telescopic arm has been designed to work with an extension up to 7 meters wide and 8.4 meters in height*. Its particular geometry enhances the characteristics for road maintenance where you want a combination of mowing roadside and finishing work far from the roadside. The sturdy telescopic extension allows greater work agility and maximum performance even in difficult situations.*

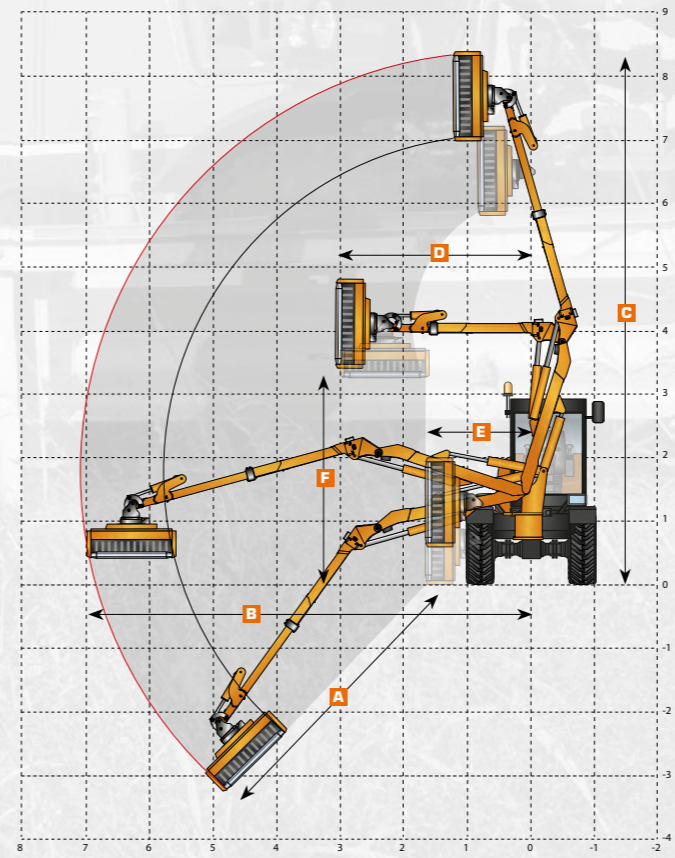

Mod.	A	B	C	D	E	F
6	3,5	6,0	7,3	3,1	1,6	3,2
7	5,3	7	8,4	3,1	1,6	3,2

* Misure variabili in base all'attrezzatura.
* Variable dimensions depending on the equipment.

Caratteristiche tecniche e costruttive soggette a modifica senza obbligo di notifica - Technical and construction specifications may be subject to change without prior notice



LAVORI DA CANTIERE CONSTRUCTION WORKS

A1

RIPRISTINI STRADALI

La **ILF KOMMUNAL** è pensata per poter disporre di attrezzature di scavo e movimento terra per rispondere in maniera rapida e completa ai frequenti lavori di ripristino o di manutenzioni stradali che un comune normalmente deve fronteggiare.

Grazie all'uso del robusto **caricatore frontale** dotato di **sgancio rapido idraulico** e di varie attrezzature terminali sempre con aggancio rapido, la macchina diventa estremamente versatile per compiere molteplici lavori come il movimento terra, il trasporto di merci su bancale, spazzatrice, ecc.

ROAD RENOVATION

The **ILF KOMMUNAL** is designed for the installation of excavating and earth moving accessories in order to satisfy completely and quickly to requests regarding road renovation and maintenance, which occur frequently in a town.

Thanks to the use of robust front loader equipped with a hydraulic quick release it's possible to attach various terminal equipment. The machine becomes extremely versatile to accomplish multiple jobs such as earth moving, the transport of goods on a pallet, sweeper, etc.



SPAZZATRICE CON BENNA DI RACCOLTA
SWEEPER WITH COLLECTING BUCKET



BENNA STANDARD
STANDARD BUCKET



A1



BENNA STANDARD
STANDARD BUCKET



FORCHE DI SOLLEVAMENTO
FORKLIFT ATTACHMENT

A1

CARICATORE FRONTALE CON ATTACCO RAPIDO FRONT LOADER WITH QUICK ATTACHMENT

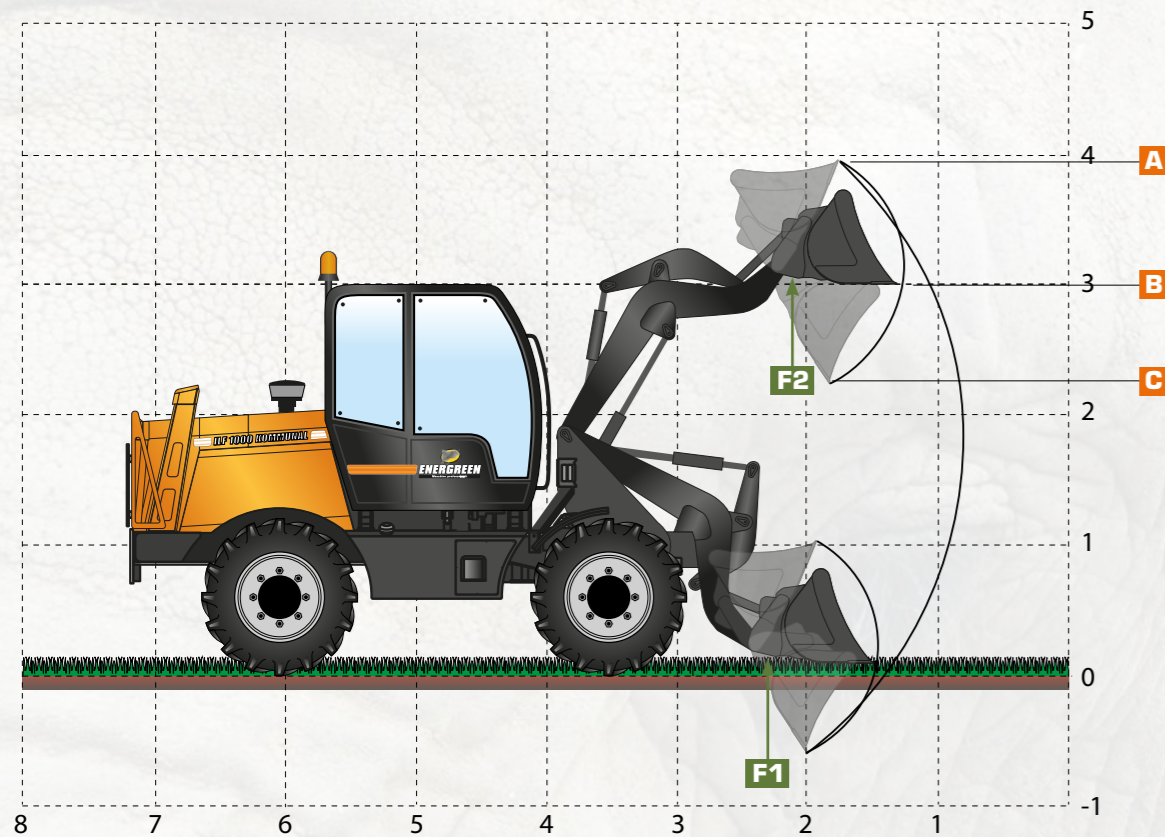

Caricatore frontale professionale con attacco rapido, dotato di sgancio rapido idraulico per le attrezzature: benna, benna miscelatrice, forche. Massima affidabilità e potenza per sollevare carichi fino quattro metri di altezza.

Front loader with quick coupling. It is equipped with hydraulic quick release for the equipment: bucket, mixer bucket, forks. Maximum reliability and lifting power up to four meters high.

A	B	C	F1	F2
3,9 m	3 m	2,3 m	6 t	3 t



BENNA STANDARD E BENNA MOD. 4X1
STANDARD BUCKET AND BUCKET MOD. 4X1



BENNA MISCELATRICE PER CALCESTRUZZO
BUCKET MIXER FOR CONCRETE



FORCHE DI SOLLEVAMENTO
FORKLIFT ATTACHMENT

SOLLEVATORE "HERCULES" A 3 PUNTI CON PTO LINKAGE "HERCULES" WITH 3-POINTS PTO

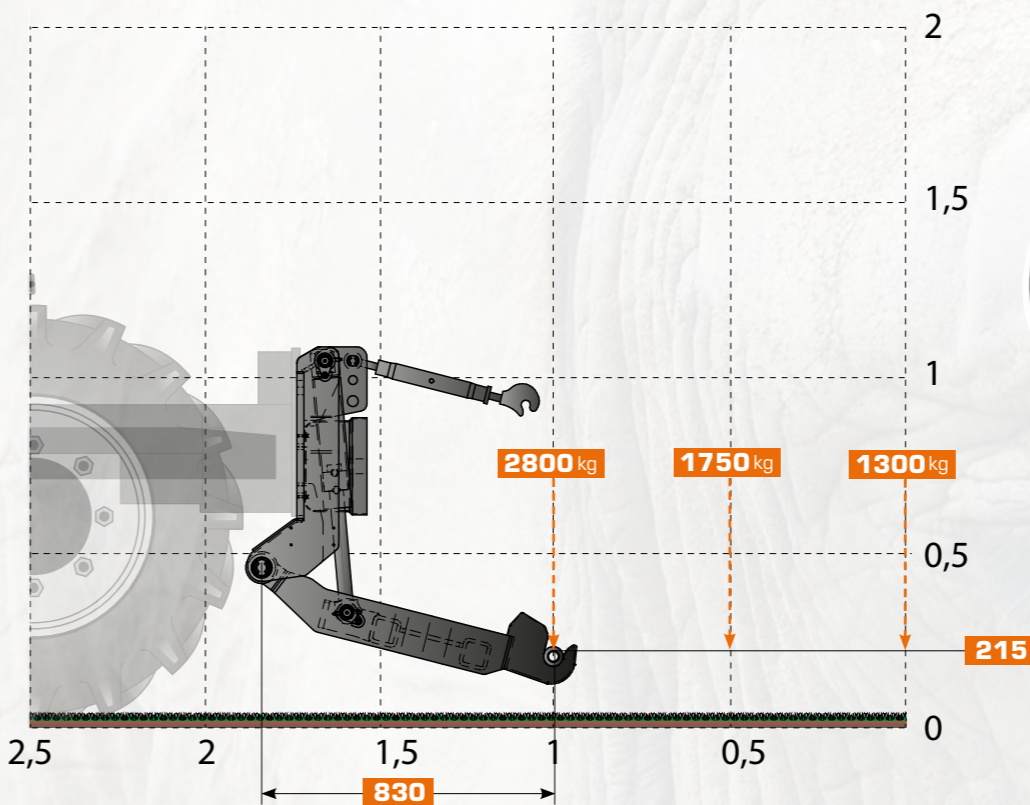

L'aggancio a 3 punti con presa di forza bidirezionale ad azionamento idraulico del sollevatore frontale HERCULES; rende questa macchina un mezzo estremamente efficace in infinite applicazioni, con la caratteristica di poter montare una vastissima gamma di attrezzature commerciali di terze parti e di poterle controllare direttamente dalla cabina, con il pieno e diretto controllo di tutte le operazioni di lavoro.

The HERCULES 3-point hitch with PTO front linkage makes the ILF Kommunal a highly efficient machine in any kind of application considering the possibility to install a wide range of commercial accessories by controlling them directly from the cabin, with full and direct control of all working operations.



FRESA
FRONT SHREDDER



FRESA LATERALE
SIDE SNOW BLOWER



KIT TRAINO CON FRENATURA IDRAULICA 10 T. O PNEUMATICA
TOW KIT WITH HYDRAULIC BRAKING 10 T. OR PNEUMATIC

A3



LA SOLUZIONE DEI PROBLEMI INVERNALI THE SOLUTION FOR WINTER PROBLEMS

AFFIDABILITÀ IN OGNI SITUAZIONE CRITICA

La gamma di accessori invernali applicabili alla **ILF KOMMUNAL** rendono la macchina particolarmente efficace per le operazioni di spargimento del sale oppure per i lavori di sgombero della sede stradale innevata.

RELIABILITY IN EVERY CRITICAL SITUATION

The wide range of winter accessories that can be installed on the **ILF KOMMUNAL** makes the machine particularly efficient for salt spreading operations and for the cleaning of roads covered with snow.



VIABILITÀ INVERNALE WINTER ROAD SERVICE



LAMA DA NEVE A SETTORE UNICO
SNOW BLADE WITH ONE SECTION



VOMERE SGOMBRANEVE
SNOW PLOUGHSHARE



FRESANEVE
SNOW BLOWER



FRESA LATERALE
SNOW BLOWER SIDE



SPARGISALE
SALT SPREADER



SPARGISALE AUTOCARICANTE
SELF LOADING SALT SPREADER

MANOVRABILITÀ MANOEUVRABILITY

QUALITÀ DEI COMPONENTI COMPONENTS QUALITY

**2 RUOTE STERZANTI
2 STEERING WHEELS**

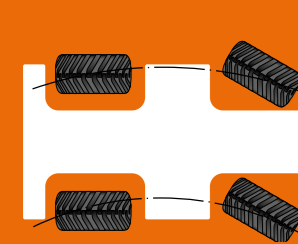

**4 RUOTE STERZANTI
4 STEERING WHEELS**

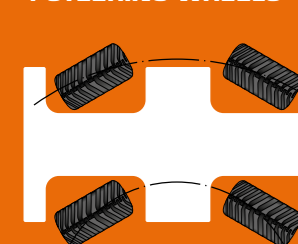

**MODALITÀ A GRANCHIO
CRAB STEERING**

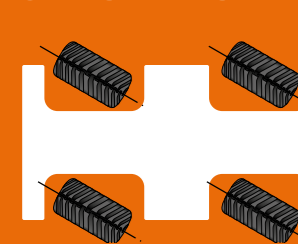

**AGILITÀ E PRECISIONE
NELLE MANOVRE**

La natura polivalente di questa macchina si evince anche dal sistema di trazione a 4 ruote motrici, tutte sterzanti, configurabili idraulicamente da comando in cabina in 3 diverse modalità operative:

- **2 ruote sterzanti anteriori**, per la massima agilità sui trasferimenti su strada.
- **4 ruote sterzanti**, sistema che dimezza il raggio di sterzata della macchina, adatto al lavoro in spazi ristretti.
- **4 ruote sterzanti parallele** (detta anche a granchio), utile per movimentare particolari attrezzature od allontanarsi da un ostacolo.

**AGILITY
AND PRECISION
IN ALL MANEUVERS**

The polyvalent nature of this machine emerges also from the traction system of the four driving and steering wheels, that can be chosen hydraulically through a device placed inside the cabin according 3 different operative modalities:

- **2 front steering wheels**, for the maximum agility during road transfers.
- **4 steering wheels**, by halving the steering range of the machine, suitable for work in narrow areas.
- **4 parallel steering wheels** (called also crab maneuver), that is very useful for the movement of specific accessories or for the moving away from an obstacle.



**5 IMPIANTI IDRAULICI
INDIPENDENTI**

1. TRASLAZIONE
2. TESTATA TRINCIANTE
3. STERZATURA
4. FRENATURA
5. FUNZIONI BRACCIO

**5 INDEPENDENT
HYDRAULIC SYSTEMS:**

1. MOVEMENT
2. CUTTING HEAD
3. STEERING
4. BRAKING
5. ARM FUNCTIONS

**VALVOLA BLOCCO OSCILLAZIONE ASSE
CON COMANDO IN CABINA**

AXIS SWING LOCK VALVE OPERATED FROM THE CAB

**FILTRO IN ALTA PRESSIONE
IN ENTRATA AL DISTRIBUTORE**

INLET HIGH PRESSURE FILTER TO THE DISTRIBUTOR

**TELAIO HD-FRAME
IN STRENX**

HD-FRAME IN STRENX

**ASSE ANTERIORE FISSO
FIXED FRONT AXLE**

**BLOCCAGGIO DIFFERENZIALE
ANTERIORE E POSTERIORE AL 100%**

100% FRONT AND REAR DIFFERENTIAL LOCKING

**TRAZIONE
INTEGRALE 4X4**

4X4 FULL WHEEL DRIVE

**FRENO NEGATIVO DI STAZIONAMENTO
(ANTERIORE)**

NEGATIVE PARKING BRAKE (FRONT AXLE)

**TRASMISSIONE IDROSTATICA
HYDROSTATIC TRANSMISSION**

FRENI DI SERVIZIO IDRAULICI A 6 DISCHI

6-DISC HYDRAULIC SERVICE BRAKES

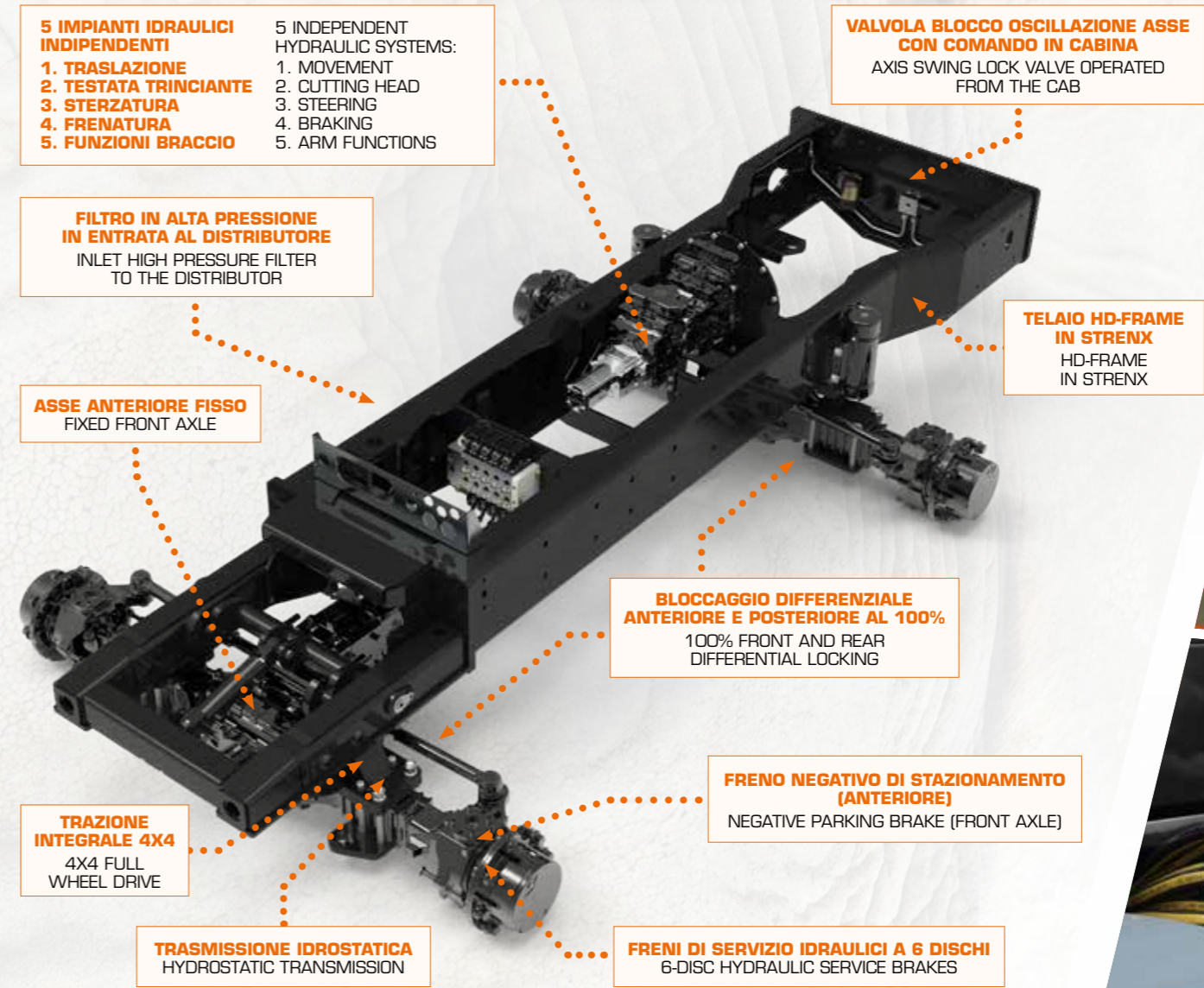

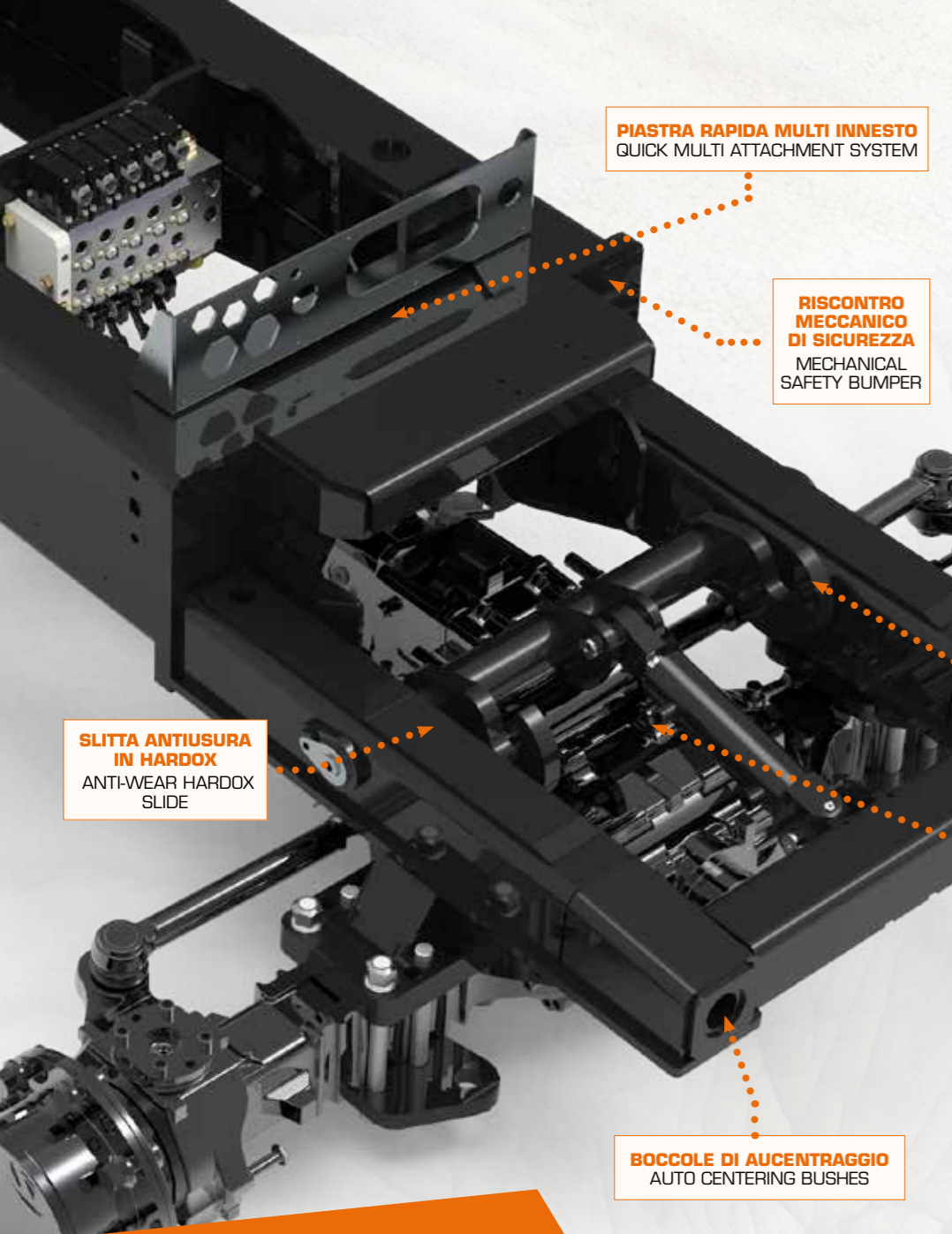

PIASTRA RAPIDA MULTI INNESTO
QUICK MULTI ATTACHMENT SYSTEM

RISCONTRO MECCANICO DI SICUREZZA
MECHANICAL SAFETY BUMPER

SLITTA ANTIUSURA IN HARDOX
ANTI-WEAR HARDOX SLIDE

BOCCOLE DI AUCCENTRAGGIO
AUTO CENTERING BUSHES

CONNECT

SISTEMA DI ATTACCO RAPIDO DELLE ATTREZZATURE

QUICK ATTACHMENT SYSTEM

Il sistema di attacco rapido "CONNECT" esclusivo della **ILF KOMMUNAL**, permette di agganciare le attrezzature frontali in modo semplice e veloce restando seduti in cabina. È composto da due slitte in Hardox integrate nel telaio con due boccole per l'autocentraggio della attrezzatura, una valvola di blocco con pistone che permette di chiudere i due ganci di sicurezza e da un'unica piastra multi innesto per tutti i collegamenti idraulici.

The exclusive "CONNECT" quick attachment system makes it easy to install frontal equipment while sitting in the cabin. Consists of two Hardox slides integrated into the chassis with bushings for the self-centering of the equipment. A piston lock valve that allows to close the two safety hooks and a single multi-clutch plate allows all hydraulic connections.

PIASTRA MULTI INNESTO
MULTI ATTACHMENT PLATE

GANCI DI SICUREZZA
SAFETY HOOKS

VALVOLA DI BLOCCO DI SICUREZZA
SAFETY LOCK VALVE



AUTO LUBE OPTIONAL

SISTEMA DI INGRASSAGGIO AUTOMATICO BRACCIO

AUTOMATIC GREASING SYSTEM OF THE ARM

I martinetti idraulici sono composti da una testata idraulica con **saldatura a frizione (1)** con all'interno una speciale **boccola cementata (2)** in acciaio fermata da un perno in acciaio temperato. L'auto lubrificazione è garantita dalla bagnatura fatta su tutte le boccole attraverso un sistema programmato di ingrassaggio automatico, "AUTO LUBE", che consente una riduzione dei tempi di manutenzione.

The hydraulic cylinders are composed of a hydraulic head with **friction welding (1)** with a special steel **cement bushing (2)**, which is held by a tempered steel pin. Auto lubrication is guaranteed by the greasing on all bushes through a programmed **automatic lubrication system**, which reduces maintenance times.

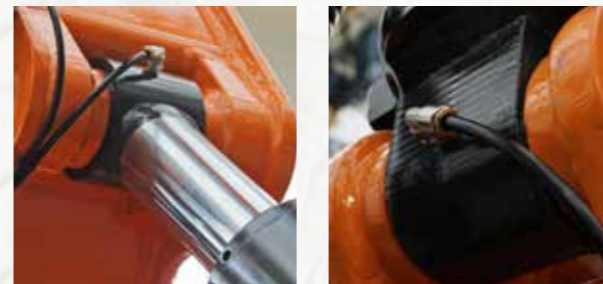

1 SALDATURA A FRIZIONE

FRICITION WELDING

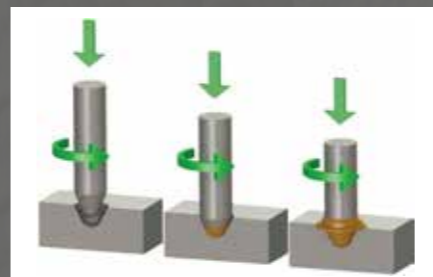

TESTATA MARTINETTO IDRAULICO CON SALDATURA A FRIZIONE
HYDRAULIC JACK HEAD WITH FRICTION WELDING

2

BOCCOLA CEMENTATA IN ACCIAIO
CEMENTED STEEL BUSH

PERNO IN ACCIAIO TEMPERATO
TEMPERED STEEL PIN

GUARNIZIONI
SEALS





MIGLIORI PRESTAZIONI ED EFFICIENZA DEI CONSUMI
THE BEST PERFORMANCE AND FUEL EFFICIENCY

L'efficacissimo sistema **CLEANFIX*** consente di soffiare via i residui polverosi che ostruiscono le griglie dei radiatori di raffreddamento, migliorando il rendimento.



The **CLEANFIX*** system is very efficient and allows to blow away the dusty residues that block the cooling radiators grids, improving the performance of the machine.

*OPTIONAL

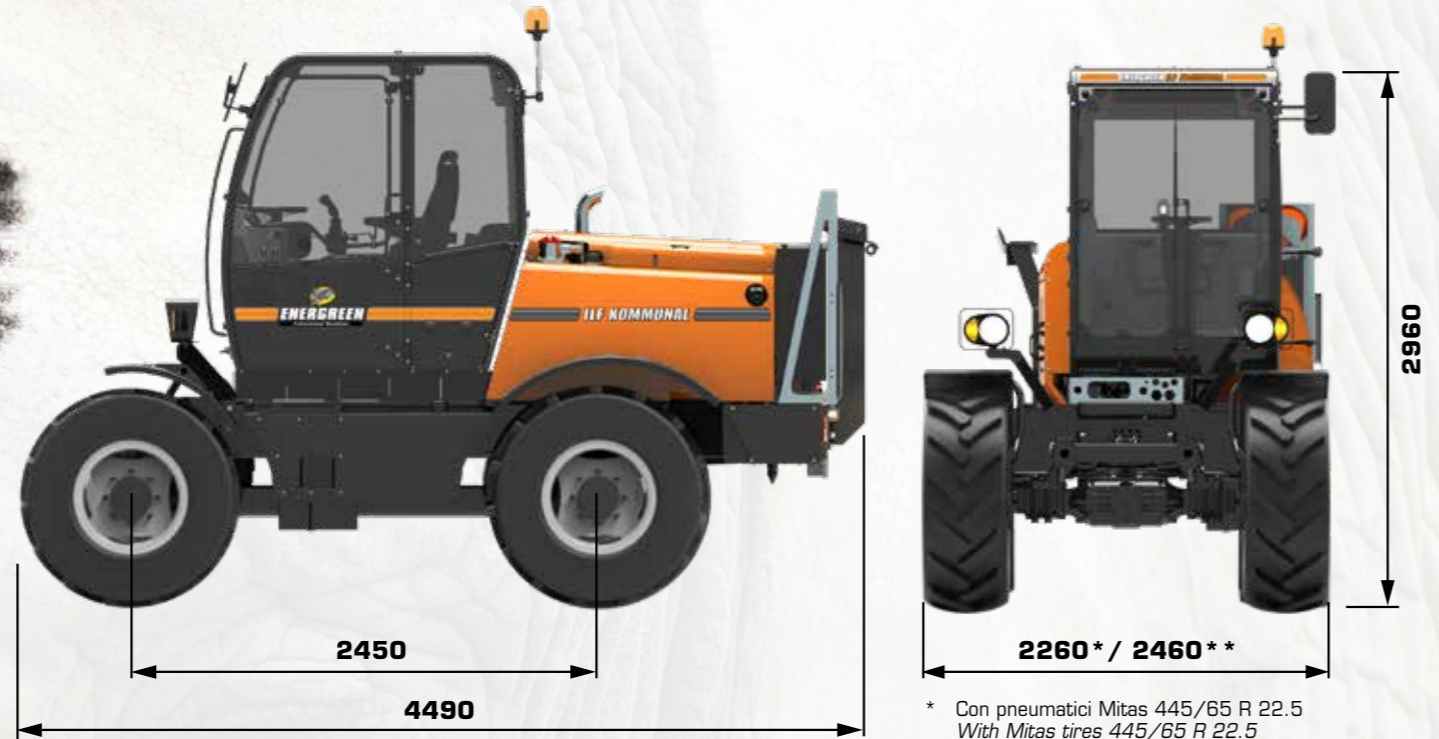

* Con pneumatici Mitas 445/65 R 22.5
With Mitas tires 445/65 R 22.5
** Con pneumatici Alliance 600/50 R 22.5
With Alliance tires 600/50 R 22.5

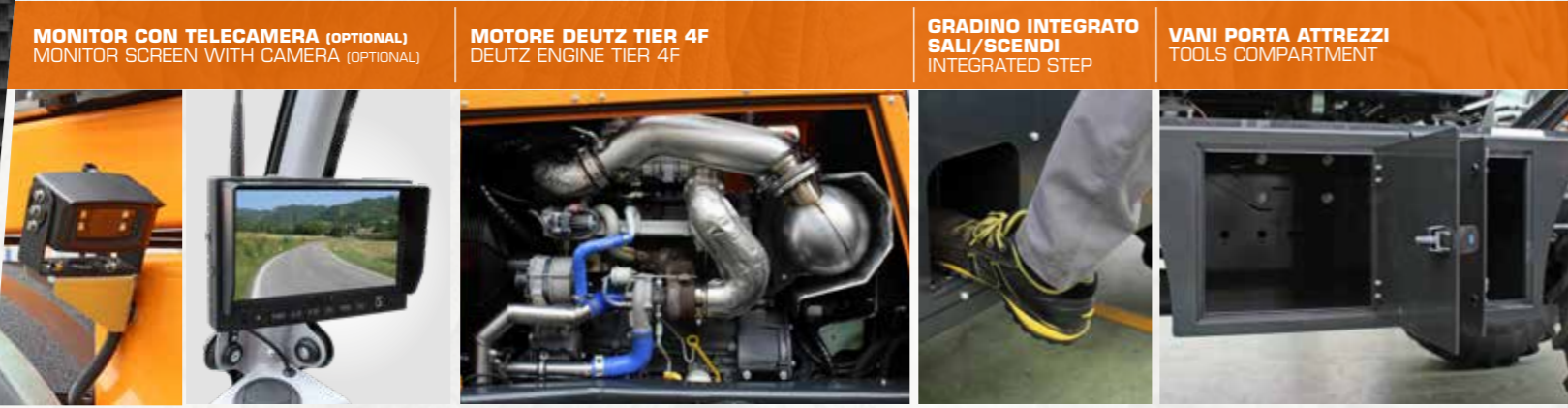

MONITOR CON TELECAMERA (OPTIONAL)
MONITOR SCREEN WITH CAMERA (OPTIONAL)

MOTORE DEUTZ TIER 4F
DEUTZ ENGINE TIER 4F

GRADINO INTEGRATO SALI/SCENDI
INTEGRATED STEP

VANI PORTA ATTREZZI
TOOLS COMPARTMENT

DATI TECNICI / TECHNICAL DATA

CABINA / CABIN

Omologazione cabina / Cabin homologation	ROPS - FOPS (1° Livello)
Volante / Steering Wheel	Regolabile / Adjustable
Manipolatore multifunzione / Joystick	Elettronico / Electronic
Lampada rotante / Rotary lamp	Commutatore interno cabina / Switch inside the cabin
Aria condizionata / Air conditioning	Elettronica / Electronic
Vetri posteriori cabina / Rear glasses	Oscurati / Darkened anti UV
Sedile regolabile / Adjustable seat	Pneumatico / Air suspension
Presse elettrica servizi / Power socket	12 V
Staccabatterie / Battery switch	Automatico / Automatic

MOTORE / ENGINE

Marca / Brand	Deutz TCD 3.6
Modello / Type	4 Cilindri Diesel / 4 Cylinders Diesel
Potenza / Power	136 hp (100 kw)
Iniezione / Injection	Common Rail a 4 valvole per cilindro / 4 valves for cylinder
Emissioni / Exhaust Emissions	EPA TIER 4f
Alternatore / Alternator	120 A.
Capacità carburante / Fuel Tank capacity	180 litri / litres
Ventola / Fan	CLEANFIX (optional) Reversibile autopulente / Reversible self cleaning
Pre-riscaldamento aria aspirazione / Pre-heating air engine intake	
Radiatore intercooler aria-aria / Air intercooler radiator	
Radiatore rinforzato liquido refrigerante / Reinforced cooler radiator	
Computer di bordo dati del motore / Computer for visualization engine data	

IMPIANTO IDRAULICO / HYDRAULIC SYSTEM

Pompa e motori in circuito chiuso / Pumps and Motors in closed circuits	
Pompa Testata trinc. / Cutting head pump	Pistoni / Piston
Pompa Traslazione / Translation pump	Pistoni / Piston

Pompa e motori in circuito aperto / Pumps and Motors in open circuits

Movimenti braccio / Arm movement	Ingranaggi / Gear
Impianto freni / Brakes system	Ingranaggi / Gear
Impianto sterzo / Steering system	Ingranaggi / Gear
Distributore idraulico / Hydraulic distributor	5 sezioni / sections
Olio idraulico / Hydraulic oil	ISOVG H46
Pressione olio / Oil Pressure	210 - 290 bar (con testata trinciante/for cutting head)

TRASMISSIONE E FRENI / TRANSMISSION AND BRAKES

Trasmissione / Transmission	Idrostatica / Hydrostatic
Trazione / Traction	4x4 Permanente / 4x4
Raggio di sterzata / Steering radius	2,15 m
Pneumatici / Tires	Standard: 445/65 R 22,5
Variatione velocità / Speed variation	0 - 40 km/h (continuous)
Cambio meccanico / Manual Gearbox	2 rapporti / 2 gears
Allineamento ruote / Wheel Alignment	Elettronico / electronic control
Asse anteriore / Front axle	Oscillante / Oscillating
Bloccaggio / front axle block	Idraulico / Hydraulic
Assi sterzanti / Steering axles	2 assi / 2 steering axles
Bloccaggio differenziale / Axle block	Anteriore / Front 100%
	Posteriore / Rear 100%
Freno stazionamento / Parking brake	Negativo / Negative
Freni di servizio / Service brakes	6 dischi / 6 discs

DIMENSIONI E PESO / SIZE AND WEIGHT

Altezza / Height	2,96 m
Larghezza / Width	2,26 / 2,46 m
Lunghezza / Length	4,49 m
Interasse / Wheelbase	2,45 m
Peso macchina / Machine Weight	6.520 kg (Senza attrezzi / Without equipment)
	10.000 kg (Con attrezzi / With equipment)

Caratteristiche tecniche e costruttive soggette a modifica senza obbligo di notifica. Technical and construction specifications may be subject to change without prior notice.

MACCHINA POLIVALENTE PER 1000 APPLICAZIONI

MACCHINA POLIVALENTE

ILF KOMMUNAL è una macchina polivalente, indispensabile per chi utilizza attrezzature diverse per molteplici lavori. Può essere configurata con estrema rapidità con il sistema di aggancio rapido delle attrezzature. La vasta gamma di accessori a disposizione, la rende impareggiabile dal punto di vista dell'investimento economico, a confronto con un trattore agricolo, per la manutenzione del verde e la viabilità invernale, e di macchine dedicate come motospazzatrice, carrello elevatore o pala gommata, ecc.

ILF KOMMUNAL resta la scelta migliore, per un utilizzo durante tutto l'anno, **un unico mezzo multifunzionale!**

TRATTORE + ATTREZZATURE

TRACTOR + ACCESSORIES



MACCHINE DEDICATE

SPECIALIZED MACHINES

POLYVALENT MACHINE FOR 1000 APPLICATIONS

... E MOLTO ALTRO ANCORA

...AND MUCH MORE

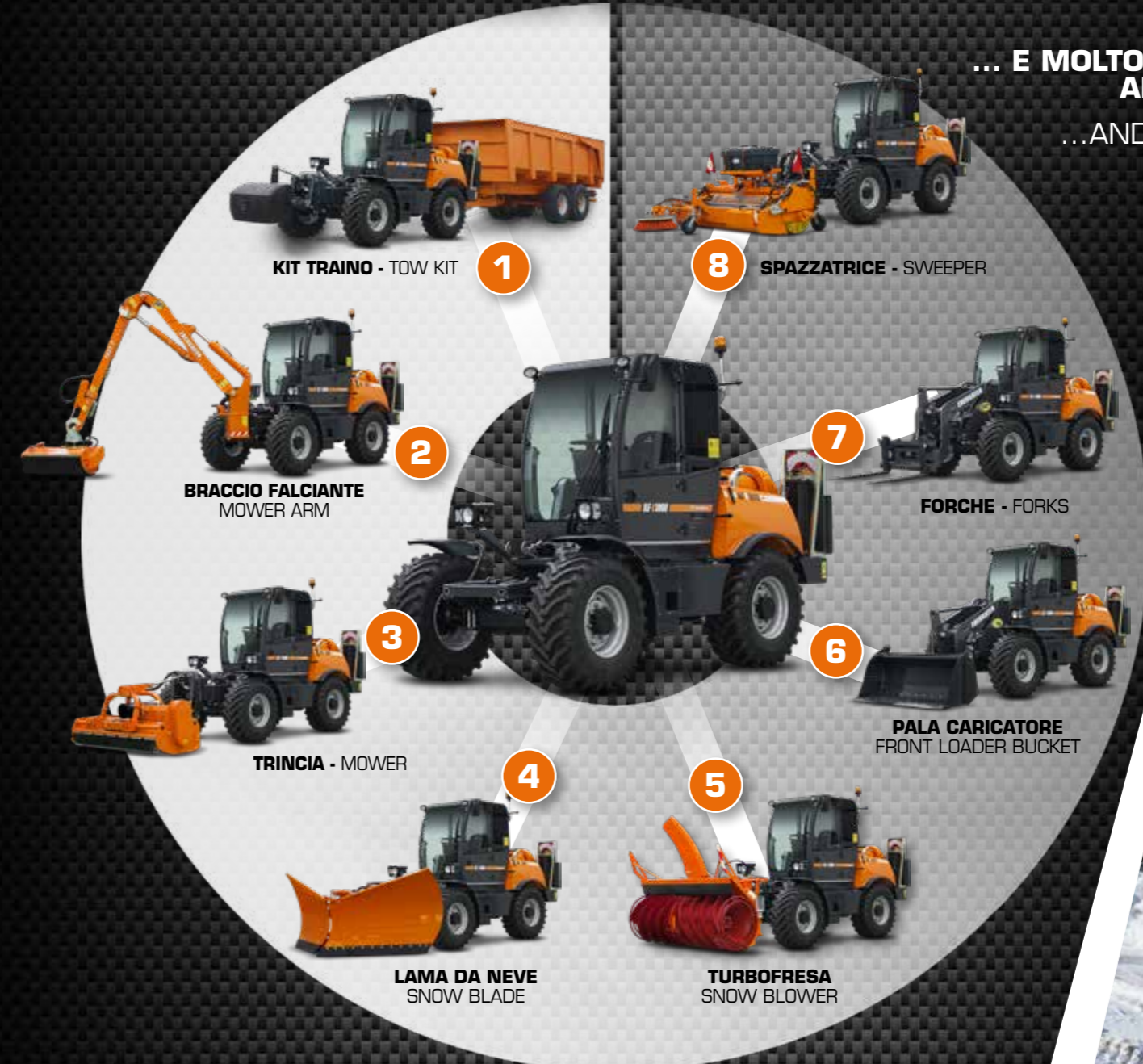

POLYVALENT MACHINES

ILF KOMMUNAL is a multifunctional machine, indispensable for those who use different equipment for multiple jobs. It can be configured very quickly with the quick coupling system of the equipment. The wide range of accessories available makes it unparalleled from the point of view of the economic investment compared to an agricultural tractor. It can be used for vegetation and winter roads maintenance, it can replace dedicated machines such as sweepers, forklifts or wheel loaders, etc.

ILF KOMMUNAL is the best choice for a year-round use, a **unique multifunctional tool!**





Concessionario di zona / Local dealership



ENERGREEN[®]
Professional Machines



ENERGREEN SRL

Via Pietre, 73

36026 Cagnano di Pojana Maggiore (VI) - ITALY

Tel. +39 0444 1511200

Fax +39 0444 1511252

www.energreen.it

commerciale@energreen.it



ILF KOMMUNAL